

#18098

Structural Calculations for:

# Wen Residence Detached Garage

8529 West Mercer Way  
Mercer Island, WA



09/20/2019

Design Criteria: IBC 2015  
Roof Snow Load = 25 psf  
Seismic:  $S_s = 1.466$ ,  $S_1 = 0.557$ , SDC = D, R = 5

Architect: PB Architects Inc., P.S.  
5506 6<sup>th</sup> Avenue South  
Seattle, WA 98108  
Ph. (206) 443-9790

Geotechnical Engineer: PanGEO Incorporated  
3213 Eastlake Avenue East, Suite B  
Seattle, WA 98102  
Ph. (206) 262-0370

**Wen Residence – Garage and Shoring**  
**8529 West Mercer Way**  
**Mercer Island, Washington****DESIGN SUMMARY:**

The proposed project is a single-family residence, with a detached garage, and accessory shoring elements to achieve foundation elevations. The CT Engineering scope of work includes design of a detached concrete garage structure and excavation shoring. Design of the wood structure is by others. Note that the garage structure and the excavation shoring have been provided with their own set of structural drawings so that they may have individual permitting tracts if needed by local jurisdiction.

The detached garage structure is a concrete structure. The concrete basement walls have been designed for permanent soil pressures. Although these walls receive benefit of the shoring piles – these benefits have been neglected. The roof of the garage structure is an elevated reinforced concrete two-way slab. Soil loading over the roof has been included as a live load. Foundations are conventional spread footings. Reference the geotechnical engineering report dated February 8, 2018 prepared by PanGEO incorporated (reference 17-405) for soil loading and foundation parameters.

The proposed foundation elements for both the house and the detached garage are founded at an elevation that require excavation shoring. Soldier piles with pipe braces have been designed to achieve the garage foundation elevation. Additional cantilever soldier piles have been designed both the temporary condition to achieve foundation elevation for the house footings and have for the final condition with finished grades and seismic surcharge.

Feel free to phone with any questions during the review process pertaining to the construction documents and/or any accessory documents.

The following computer design software may have been used for various components:

Excel  
Enercalc  
Quickwall  
Ram Concept

Note that various software releases may have been used. Where software references standards prior to current code cycle, various design parameters including load factors, load combinations, allowable design stresses, etc., have been verified to meet or exceed those as referenced by the current code.

Project: #19008

Date: \_\_\_\_\_

Client: WEN Central

Page Number: \_\_\_\_\_

H DESIGN = 16'

$ER = (7)H = 112$  PSF

$P_a \leq 55$  PCF

(16)(55) ~ 880  
(6)(55) ~ 330

$330 + 550 = 880$

(1130) =

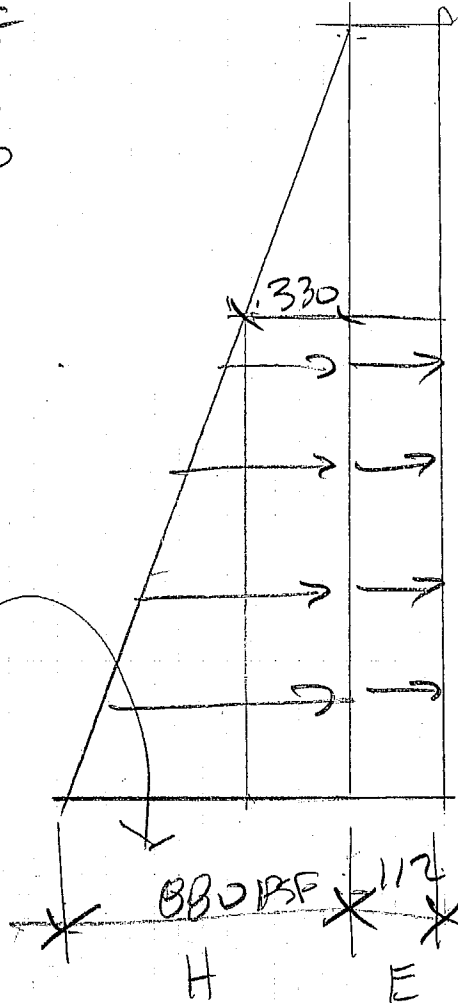

SHORING FOR STRG DWGS/CALCS

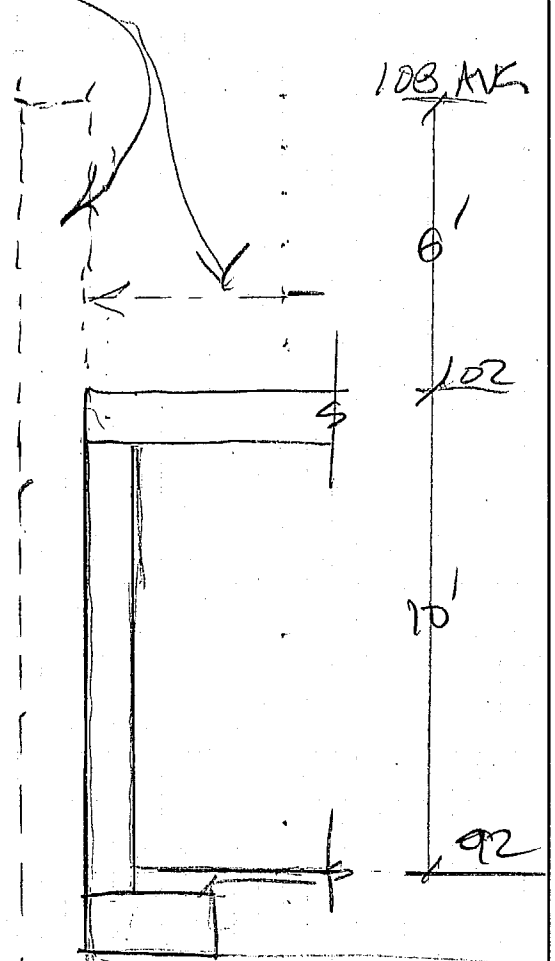

ADD LID DL + U(2' SOIL)

12' TW

$DL = (12)(150) = 1800$

$LL = (12)(2 \times 125) = 3000$

$\Sigma = 4800$

+ 8" wall DL = 1000

$\Sigma = 5800$

NOTE:

2' SOIL COVER OVER 4" EPS FOAM

PTR WIDTH

$5800 / 3000 = 1.9$

2'-0" ~~FOAM~~

Project: #1909B

Date: 2019 SEPT

Client: WEN GARAGE

Page Number:

WALL: DESIGN FOR SIMPLE SPAN MOMENT (conservative)

$$M_E \leq \frac{w_e l^2}{8} = \frac{(112 \text{ KSF})(10)^2}{8} = 1.4 \text{ K.Ft}$$

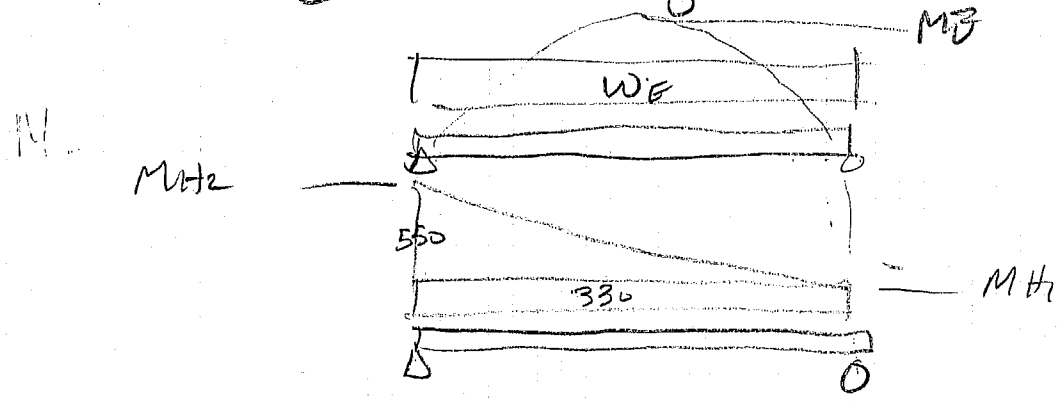

$$M_{H1} = \frac{w l^2}{8} = \frac{(330)(10)^2}{8} = 4.125 \text{ K.Ft}$$

$$M_{H2} = \frac{2Wl}{9\sqrt{3}} = \frac{(2)(\overbrace{1/2}^{2735 \text{ K}})(550)(10)}{9\sqrt{3}} = 3.53 \text{ K.Ft}$$

LOAD COMBOS

$$1.2 D + 1.6 (L + H)$$

$$1.2 D + 1.6 E + 1.6 H \quad \leftarrow \text{controls}$$

$$M_u = (1.0)(1.4) + (1.6)(4.125 + 3.53) = 1.4 + 12.248 = 13.648 \text{ K.Ft/Ft}$$

Size wall for  $\phi M_n \geq 13.75 \text{ K.Ft/Ft}$

$\phi =$

Project: \_\_\_\_\_

Date: \_\_\_\_\_

Client: \_\_\_\_\_

Page Number: \_\_\_\_\_

WALL THICKNESS OPTIONS

$f'_c = 4000$  &  $f_y = 60,000$

Ⓐ 12" wall w/ #5 @ 12" c/c ~~IF~~ IF  $d = 10.5$   $A_s = 0.31$

$$a = \frac{A_s F_y}{0.85 F'_c b} = 0.456"$$

$$\phi M_n = 0.9 [A_s f_y (d - a/2)] = 168.13 \text{ k.in} = 14.0 \text{ k.ft}$$

Ⓑ 10" wall w/ #5 @ 10" c/c  $d = 8.5$   $A_s = 0.372 \text{ in}^2$

$$a = 0.547$$

$$\phi M_n = 176.24 \text{ k.in/ft} = 14.68 \text{ k.ft/ft}$$

Ⓒ 8" wall w/ #5 @ 6" c/c  $A_s = 0.62 \text{ in}^2$  (IF)  $d = 6.5$

$$a = 0.912 \text{ in}$$

$$\phi M_n = 202 \text{ k.in} = 16.86 \text{ k.ft/ft}$$

use 8" MIN wall thickness

#5 @ 6" IF

#5 @ 12" OF

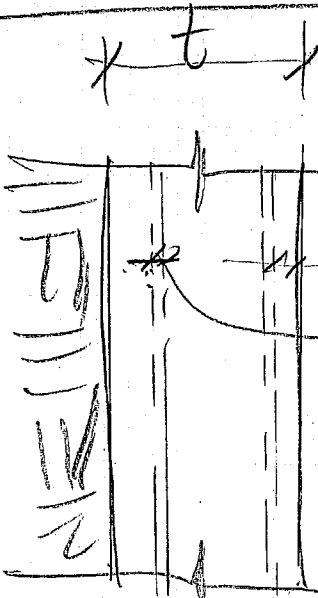

1" cover IF

2" cover OF

$$+d \geq t - 1.5" \text{ (up to door)} \leq 1"$$

$$-d \geq t - 2.5"$$

Project: #19098

Date:

Client: WEN GARAGE

Page Number:

GARAGE HDR

Opening = 18'-4" R.O.  
TW = 22/2 = 11'

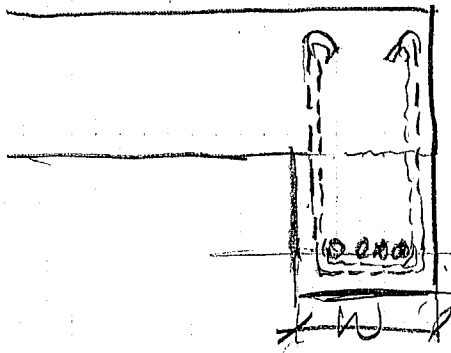

FOR Bm WIDTH = 12"  
1/2 COVER #4 TIES  
12 - 2(1.5+5) = 8"

MAX → (4) #8 bars  
(4)(1.0) + (3)(1.0 min) = 7"

DL = 12" SLAB = (12/12)(150)(11) = 1.65 KIF

$M_{DL} = \frac{wL^2}{8} = 69.3 \text{ K.Ft}$   
 $R_{DL} = \frac{14.05}{8}$

LL = 2' SOIL = (2)(125)(11) = 2.75 KIF

$M_{LL} = \frac{wL^2}{8} = 115.5 \text{ K.Ft}$   
 $R_{LL} = 24.75$

SNOW = 25 PSF       $w_{snow} = (0.25)(11) = 0.275$

$M_{snow} = 11.55 \text{ K.Ft}$   
 $R_{snow} = 2.5$

LOAD COMBOS:

1.2 D + 1.6 L + 0.5 S      ← CONTROLS

1.2 D + 1.0 E + 1.0 L + 0.7 S

$M_u = (1.2)(69.3) + (1.6)(115.5) + (0.5)(11.55) = 274 \text{ K}$

$V_u = (1.2)(14.05) + (1.6)(24.75) + (0.5)(2.5) = 58.7 \text{ K}$

Project: # 1909B

Date: \_\_\_\_\_

Client: \_\_\_\_\_

Page Number: \_\_\_\_\_

WDR:  $f'_c = 4000$   $f_y = 60,000$   
 $b = 12$   $h = 24$   $d = 21.5"$   
 (4) #8  $A_s = (4)(0.79) = 3.16$   
 $a = \frac{f_s f_y}{(0.85) f'_c b} = 4.647"$   
 $\phi M_n = 0.9 [A_s f_y (d - a/2)] = 3272 \text{ K-in}$   
 $= 272 \text{ K-ft} \checkmark$   
 (99.5%) OK

$V_c = 2 \sqrt{f'_c} b w d = 32,634 \text{ K}$	$A_s$
$V_s = \frac{A_v f_y d}{s}$	(2) Leg #4 @ 6" 0.4
	(2) Leg #3 @ 4" 0.22

#4  $V_s = (4)(60)(21.5)/6 = 86 \text{ K}$   
 #3  $V_s = (0.22)(60)(21.5)/4 = 70.95 \text{ K}$   
 $\phi (V_c + V_s) = 0.75 (32.63 + 70.95) = 77.7 \text{ K}$

∴ USE 12x24 BEAM  
 w/ (4) #8 BOT  
 #3 TIES @ 4" OC

Title :  
Dsgnr:  
Description :

Job #  
Date: 4:41PM, 19 SEP 19

Scope :

Rev: 580008  
User: KW-0602997, Ver 5.8.0, 1-Dec-2003  
(c)1983-2003 ENERCALC Engineering Software

## Concrete Rectangular & Tee Beam Design

Page 1  
19098.ecw:Calculations

**Description** GARAGE HDR 4

### General Information

Code Ref: ACI 318-02, 1997 UBC, 2003 IBC, 2003 NFPA 5000

Span	18.33 ft	f'c	4,000 psi
Depth	24.000 in	Fy	60,000 psi
Width	12.000 in	Concrete Wt.	145.0 pcf
		Seismic Zone	0
		End Fixity	Pinned-Pinned
Beam Weight Added Internally		Live Load acts with Short Term	

### Reinforcing

Rebar @ Center of Beam...				Rebar @ Left End of Beam...				Rebar @ Right End of Beam...			
Count	Size	'd' from Top		Count	Size	'd' from Top		Count	Size	'd' from Top	
#1	3	8	3.00 in	#1	3	8	3.00 in	#1	4	8	3.00 in
#2	4	8	21.50 in	#2	4	8	21.50 in	#2	3	8	21.50 in

### Load Factoring

Note: Load factoring supports 2003 IBC and 2003 NFPA 5000 by virtue of their references to ACI 318-02 for concrete design.  
Factoring of entered loads to ultimate loads within this program is according to ACI 318-02 C.2

### Uniform Loads

	Dead Load	Live Load	Short Term	Start	End
#1	1.650 k	2.650 k	k	0.000 ft	18.330 ft

### Summary

**Beam Design OK**

Span = 18.33ft, Width= 12.00in Depth = 24.00in

Maximum Moment : Mu	275.85 k-ft	Maximum Deflection	-0.4548 in
Allowable Moment : Mn*phi	276.38 k-ft		
Maximum Shear : Vu	48.64 k	Max Reaction @ Left	42.07 k
Allowable Shear : Vn*phi	48.64 k	Max Reaction @ Right	42.07 k
<b>Shear Stirrups...</b>			
Stirrup Area @ Section	0.110 in <sup>2</sup>		
Region	0.000	3.055	6.110
Max. Spacing	5.468	8.820	10.500
Max Vu	48.638	40.452	20.226
			9.165
			12.220
			15.275
			18.330 ft
			5.593 in
			39.970
			48.157 k

### Bending & Shear Force Summary

Bending...	Mn*Phi	Mu, Eq. C-1	Mu, Eq. C-2	Mu, Eq. C-3
@ Center	276.38 k-ft	275.85 k-ft	206.89 k-ft	73.33 k-ft
@ Left End	276.38 k-ft	0.00 k-ft	0.00 k-ft	0.00 k-ft
@ Right End	211.03 k-ft	0.00 k-ft	0.00 k-ft	0.00 k-ft
Shear...	Vn*Phi	Vu, Eq. C-1	Vu, Eq. C-2	Vu, Eq. C-3
@ Left End	48.64 k	48.64 k	36.48 k	12.93 k
@ Right End	48.16 k	48.16 k	36.12 k	12.80 k

### Deflection

Deflections...	Upward		Downward	
DL + [Bm Wt]	0.0000 in	at 0.0000 ft	-0.1665 in	at 9.1650 ft
DL + LL + [Bm Wt]	0.0000 in	at 0.0000 ft	-0.4548 in	at 9.1650 ft
DL + LL + ST + [Bm Wt]	0.0000 in	at 0.0000 ft	-0.4548 in	at 9.1650 ft
Reactions...	@ Left		@ Right	
DL + [Bm Wt]	17.780 k		17.780 k	
DL + LL + [Bm Wt]	42.067 k		42.067 k	
DL + LL + ST + [Bm Wt]	42.067 k		42.067 k	



Title :  
 Dsgnr:  
 Description :

Job #  
 Date: 4:41PM, 19 SEP 19

Scope :

Rev: 580008  
 User: KW-0602997, Ver 5.8.0, 1-Dec-2003  
 (c)1983-2003 ENERCALC Engineering Software

## Concrete Rectangular & Tee Beam Design

Page 2  
 19098.ecw:Calculations

Description GARAGE HDR 4

### Section Analysis

	Center	Left End	Right End
<b>Evaluate Moment Capacity...</b>			
X : Neutral Axis	4.100 in	4.100 in	3.425 in
a = beta * Xneutral	3.485 in	3.485 in	2.911 in
Compression in Concrete	142.188 k	142.188 k	118.779 k
Sum [Steel comp. forces]	47.261 k	47.261 k	23.370 k
Tension in Reinforcing	-189.600 k	-189.600 k	-142.200 k
<b>Find Max As for Ductile Failure...</b>			
X-Balanced	12.724 in	12.724 in	12.7245 in
Xmax = Xbal * 0.75	9.543 in	9.543 in	9.543 in
a-max = beta * Xbal	10.816 in	10.816 in	10.816 in
Compression in Concrete	330.964 k	330.964 k	330.964 k
Sum [Steel Comp Forces]	133.315 k	133.315 k	177.754 k
Total Compressive Force	464.279 k	464.279 k	508.718 k
AS Max = Tot Force / Fy	7.738 in <sup>2</sup>	7.738 in <sup>2</sup>	8.479 in <sup>2</sup>
Actual Tension As	3.160 <b>OK</b>	0.000 <b>OK</b>	0.000 <b>OK</b>

### Additional Deflection Calcs

Neutral Axis	6.990 in	Mcr	45.54 k-ft
Igross	13,824.00 in <sup>4</sup>	Ms:Max DL + LL	192.77 k-ft
Icracked	7,021.64 in <sup>4</sup>	R1 = (Ms:DL+LL)/Mcr	0.236
Elastic Modulus	3,605.0 ksi	Ms:Max DL+LL+ST	192.77 k-ft
Fr = 7.5 * fc <sup>.5</sup>	474.342 psi	R2 = (Ms:DL+LL+ST)/Mcr	0.236
Z:Cracking	168.870 k/in	I:eff... Ms(DL+LL)	7,111.297 in <sup>4</sup>
Z:cracking > 145 : Interior Only !		I:eff... Ms(DL+LL+ST)	7,111.297 in <sup>4</sup>
Eff. Flange Width	12.00 in		

### ACI Factors (per ACI 318-02, applied internally to entered loads)

ACI C-1 & C-2 DL	1.200	ACI C-2 Group Factor	0.750	Add'l "1.4" Factor for Seismic	1.400
ACI C-1 & C-2 LL	1.600	ACI C-3 Dead Load Factor	0.900	Add'l "0.9" Factor for Seismic	0.900
ACI C-1 & C-2 ST	0.500	ACI C-3 Short Term Factor	1.300		
....seismic = ST * :	1.100				

## WALL BENDING CAPACITY CHECK

Span	$l$	10 ft.
Thickness	$h$	8 inch
Width	$b$	12 inch

### SERVICE LOADS

Dead Load	$DL$	0 psf
Add Dead Load	$ADL$	0 psf
Live Load	$LL$	0 psf
Total load	$TL$	0 psf

Load  
Factor

### FACTORED LOADS

$DLu$	0 psf
$ADLu$	0 psf
$LLu$	0 psf
$TLu$	0 psf

Concrete Strength	$f_c$	4000 psi
Concrete Unit Weight	$w_c$	150 pcf
Conc. Mod. of Elastic.	$E_c$	3,604,997 psi

$$\beta_1 = 0.85$$

Steel Yield Strength	$f_y$	60000 psi
Conc. Mod. of Elastic.	$E_s$	29,000,000 psi

Bar size	$bar$	5 #
Depth to bar	$d$	6.5 in
Bar spacing	$s$	6 in
Bar Cover	$cover$	1.1875 in
Bar area	$As/bar$	0.31 in <sup>2</sup>
Area of Steel	$As/ft$	0.62 in <sup>2</sup> / ft

$$As_{min} = 0.26$$

$$\rho_{min} = 0.00333$$

$$\rho = 0.00795 \text{ OK}$$

$$\rho_b = 0.02851$$

$$\rho_{max} = 0.02138$$

### SIMPLE SPAN

		Service
Reaction	R	0.00 kip / ft
Shear	V	0.00 kip / ft
Moment	M	0.00 ft*kip / ft
	Ma =	0.00 in*kip / ft

### Factored

$Ru$	0.00 kip / ft
$Vu$	0.00 kip / ft
$Mu$	0.00 ft*kip / ft

Shear:  $V_c = 9.87 \text{ kip / ft}$

$$\phi V_n = 7.40 \text{ kip / ft}$$

**Shear Capacity OK**

Bending:  $a = 0.91 \text{ in}$   
 $M_n = 18.74 \text{ ft*kip / ft}$

$$\phi M_n = 16.86 \text{ ft*kip / ft}$$

**Moment Capacity OK**

NOTE: PRELIMINARY ONE WAY CHECK  
- USE TWO WAY F.E.M ANALYSIS

**SLAB GEOMETRY**

Slab Span	<i>l</i>	20 ft.
Slab Thickness	<i>h</i>	12 inch
Slab Width	<i>b</i>	12 inch

**SERVICE LOADS**

Dead Load	<i>DL</i>	150 psf
Add Dead Load	<i>ADL</i>	0 psf
Live Load	<i>LL</i>	250 psf
Total load	<i>TL</i>	400 psf

Load Factor	<b>FACTORED LOADS</b>
-------------	-----------------------

1.2	<i>DLu</i>	180 psf
1.2	<i>ADLu</i>	0 psf
1.6	<i>LLu</i>	400 psf
	<i>TLu</i>	580 psf

Concrete Strength	<i>f<sub>c</sub></i>	4000 psi
Concrete Unit Weight	<i>w<sub>c</sub></i>	150 pcf
Conc. Mod. of Elastic.	<i>E<sub>c</sub></i>	3,604,997 psi

$\beta_1 = 0.85$

Steel Yield Strength	<i>f<sub>y</sub></i>	60000 psi
Conc. Mod. of Elastic.	<i>E<sub>s</sub></i>	29,000,000 psi

Bar size	<i>bar</i>	5 #
Depth to bar	<i>d</i>	10 in
Bar spacing	<i>s</i>	8 in
Bar Cover	<i>cover</i>	1.6875 in
Bar area	<i>As/bar</i>	0.31 in <sup>2</sup>
Area of Steel	<i>As / ft</i>	0.465 in <sup>2</sup> / ft

$A_{s_{min}} = 0.40$   
 $\rho_{min} = 0.00333$   
 $\rho = 0.00388$  **OK**  
 $\rho_b = 0.02851$   
 $\rho_{max} = 0.02138$

**SIMPLE SPAN**

		<b>Service</b>			<b>Factored</b>
Reaction	R	4.00 kip / ft		<i>R<sub>u</sub></i>	5.80 kip / ft
Shear	V	4.00 kip / ft		<i>V<sub>u</sub></i>	5.80 kip / ft
Moment	M	20.00 ft*kip / ft		<i>M<sub>u</sub></i>	29.00 ft*kip / ft
		<i>Ma =</i>	240.00 in*kip / ft		

Shear:  $V_c = 15.18$  kip / ft       $\phi V_n = 11.38$  kip / ft  
**Shear Capacity OK**

Bending:  $a = 0.68$  in       $\phi M_n = 20.21$  ft\*kip / ft  
 $M_n = 22.46$  ft\*kip / ft  
**Moment Capacity Exceeded**

Midspan Deflection:	<i>l<sub>g</sub></i>	1728 in <sup>4</sup> / ft
	<i>n</i>	8.04 <i>E<sub>s</sub>/E<sub>c</sub></i>
	<i>n * As</i>	3.74
		0.00 goalseek
	<i>c</i>	2.20 in
	<i>I<sub>cr</sub></i>	270.17 in <sup>4</sup> / ft
	<i>f<sub>r</sub></i>	474.34 psi
	<i>M<sub>cr</sub></i>	136.61 in*kip / ft
	<i>l<sub>e</sub></i>	539.03 in <sup>4</sup> / ft

Service Defl. (in.)	Ratio	
$\Delta$ DL =	0.28	864 <b>OK</b>
$\Delta$ LL =	0.46	518 <b>OK</b>
$\Delta$ TL =	0.74	324 <b>OK</b>
$\lambda =$	1.68	ACI EQ(9-11)
$\Delta$ TLcreep =	0.93	258 <b>OK</b>

GARAGE ROOF TWO WAY SLAB  
F.E.M ANALYSIS

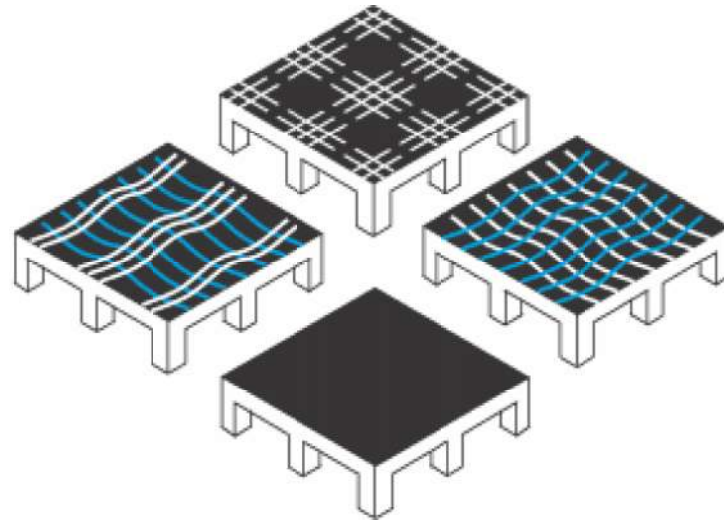

19098\_LID.cpt  
9/18/2019

# Table of Contents

Materials .....	3
Loadings .....	5
Load Combinations .....	6
Mesh Input: Standard Plan .....	11
Element: Standard Plan .....	12
Element: Slab Summary Plan .....	13
Element: Structure Summary Perspective .....	14
Self-Dead Loading: Std Reactions Plan .....	15
Live (Unreducible) Loading: All Loads Plan .....	17
Live (Unreducible) Loading: Std Reactions Plan .....	18
Live (Roof) Loading: All Loads Plan .....	20
Snow Loading: All Loads Plan .....	21
Sustained Service LC: Max Deflection Plan .....	22
Factored LC: 1.2D + 1.6L + 0.5Lr: Max Mx Plan .....	24
Factored LC: 1.2D + 1.6L + 0.5Lr: Min Mx Plan .....	26
Factored LC: 1.2D + 1.6L + 0.5Lr: Max My Plan .....	28
Factored LC: 1.2D + 1.6L + 0.5Lr: Min My Plan .....	30
Factored LC: 1.2D + 1.6L + 0.5Lr: Std Reactions Plan .....	32
Design Strip: Latitude Design Spans Plan .....	34
Design Strip: Longitude Design Spans Plan .....	36
Reinforcement: Top Bars Plan .....	37
Reinforcement: Bottom Bars Plan .....	38
Reinforcement: Individual Top Bars Plan .....	39
Reinforcement: Individual Bottom Bars Plan .....	40
Reinforcement: Detailed Bars & SSR Perspective .....	41
Reinforcement: Transparent Slab Perspective .....	42
Service Design: Latitude Status Plan .....	43
Service Design: Latitude Top Reinforcement Plan .....	44
Service Design: Latitude Bottom Reinforcement Plan .....	46
Service Design: Longitude Status Plan .....	48
Service Design: Longitude Top Reinforcement Plan .....	49
Service Design: Longitude Bottom Reinforcement Plan .....	51
Service Design: Top Stress Plan .....	53
Service Design: Centroid Stress Plan .....	55
Service Design: Bottom Stress Plan .....	57
Design Status: Status Plan .....	59
Estimate .....	60

# Materials

## Concrete Mix

Mix Name	Density (pcf)	Density For Loads (pcf)	$f'_{ci}$ (psi)	$f'_{c}$ (psi)	$f_{cui}$ (psi)	$f_{cu}$ (psi)	Poissons Ratio	$E_c$ Calc	User $E_{ci}$ (psi)	User $E_c$ (psi)
3000 psi	150	150	3000	3000	3725	3725	0.2	Code	2500000	3000000
4000 psi	150	150	3000	4000	3725	4975	0.2	Code	2500000	3000000
5000 psi	150	150	3000	5000	3725	6399	0.2	Code	2500000	3000000
6000 psi	150	150	3000	6000	3725	7450	0.2	Code	2500000	3000000

## PT Systems

System Name	Type	$A_{ps}$ (in <sup>2</sup> )	$E_{ps}$ (ksi)	$f_{se}$ (ksi)	$f_{py}$ (ksi)	$f_{pu}$ (ksi)	Duct Width (inches)	Strands Per Duct	Min Radius (feet)
1/2" Unbonded	unbonded	0.153	28000	175	243	270	0.5	1	6
1/2" Bonded	bonded	0.153	28000	160	243	270	3	4	6
0.6" Unbonded	unbonded	0.217	28000	175	243	270	0.6	1	8
0.6" Bonded	bonded	0.217	28000	160	243	270	4	4	8

## PT Stressing Parameters

System Name	Jacking Stress (ksi)	Seating Loss (inches)	Anchor Friction	Wobble Friction (1/feet)	Angular Friction (1/radians)	Long-Term Losses (ksi)
1/2" Unbonded	216	0.25	0	0.0014	0.07	22
1/2" Bonded	216	0.25	0.02	0.001	0.2	22
0.6" Unbonded	216	0.25	0	0.0014	0.07	22
0.6" Bonded	216	0.25	0.02	0.001	0.2	22

## Reinforcing Bars

Bar Name	$A_s$ (in <sup>2</sup> )	$E_s$ (ksi)	$F_y$ (ksi)	Coating	Straight Ld/Db	90 Hook Ld/Db	180 Hook Ld/Db
#3	0.11	29000	60	None	Code	Code	Code
#4	0.2	29000	60	None	Code	Code	Code
#5	0.31	29000	60	None	Code	Code	Code
#6	0.44	29000	60	None	Code	Code	Code
#7	0.6	29000	60	None	Code	Code	Code
#8	0.79	29000	60	None	Code	Code	Code
#9	1	29000	60	None	Code	Code	Code
#10	1.27	29000	60	None	Code	Code	Code
#11	1.56	29000	60	None	Code	Code	Code

# Materials (2)

## SSR Systems

<i>SSR System Name</i>	<i>Stud Area (in<sup>2</sup>)</i>	<i>Head Area (in<sup>2</sup>)</i>	<i>Min Clear Head Spacing (inches)</i>	<i>Specified Stud Spacing (inches)</i>	<i>Fy (ksi)</i>	<i>Stud Spacing Rounding Increment (inches)</i>	<i>Min Studs Per Rail</i>	<i>System Type</i>
3/8" SSR	0.11	1.11	0.5	None	50	0.25	2	Rail
1/2" SSR	0.196	1.96	0.5	None	50	0.25	2	Rail
5/8" SSR	0.307	3.07	0.5	None	50	0.25	2	Rail
3/4" SSR	0.442	4.42	0.5	None	50	0.25	2	Rail
Ancon Shearfix Auto-Size	1.217	1.096	0.5906	None	72.52	0.03937	2	Rail
Ancon Shearfix 10 mm	1.1217	1.096	0.5906	None	72.52	0.03937	2	Rail
Ancon Shearfix 12 mm	1.1753	1.578	0.5906	None	72.52	0.03937	2	Rail
Ancon Shearfix 14 mm	1.2386	2.147	0.5906	None	72.52	0.03937	2	Rail
Ancon Shearfix 16 mm	1.3116	2.805	0.5906	None	72.52	0.03937	2	Rail
Ancon Shearfix 20 mm	1.4869	4.383	0.5906	None	72.52	0.03937	2	Rail
Ancon Shearfix 24 mm	1.7012	6.311	0.5906	None	72.52	0.03937	2	Rail

# Loadings

<i>Loading Name</i>	<i>Type</i>	<i>Analysis</i>	<i>On-Pattern Factor</i>	<i>Off-Pattern Factor</i>
Self-Dead Loading	Self-Weight	Normal	1	1
Balance Loading	Balance	Normal	1	1
Hyperstatic Loading	Hyperstatic	Hyperstatic	1	1
Temporary Construction (At Stressing) Loading	Stressing Dead	Normal	1	1
Other Dead Loading	Dead	Normal	1	1
Live (Reducible) Loading	Live (Reducible)	Normal	1	0
Live (Unreducible) Loading	Live (Unreducible)	Normal	1	0
Live (Storage) Loading	Live (Storage)	Normal	1	0
Live (Parking) Loading	Live (Parking)	Normal	1	0
Live (Roof) Loading	Live (Roof)	Normal	1	0
Snow Loading	Snow	Normal	1	1



# Load Combinations

## All Dead LC

Active Design Criteria: &lt;none&gt;

Analysis: Linear

<i>Loading</i>	<i>Standard Factor</i>	<i>Alt. Envelope Factor</i>
Self-Dead Loading	1	1
Other Dead Loading	1	1

## Dead + Balance LC

Active Design Criteria: &lt;none&gt;

Analysis: Linear

<i>Loading</i>	<i>Standard Factor</i>	<i>Alt. Envelope Factor</i>
Self-Dead Loading	1	1
Balance Loading	1	1
Other Dead Loading	1	1

## Initial Service LC

Active Design Criteria: Initial Service Desig

Analysis: Linear

<i>Loading</i>	<i>Standard Factor</i>	<i>Alt. Envelope Factor</i>
Self-Dead Loading	1	1
Balance Loading	1.13	1.13
Temporary Construction (At Stressing) Loading	1	1

## Service LC: D + L

Active Design Criteria: User Minimum Design, Code Minimum Design, Service Desig

Analysis: Linear

<i>Loading</i>	<i>Standard Factor</i>	<i>Alt. Envelope Factor</i>
Self-Dead Loading	1	1
Balance Loading	1	1
Other Dead Loading	1	1
Live (Reducible) Loading	1	0
Live (Unreducible) Loading	1	0
Live (Storage) Loading	1	0
Live (Parking) Loading	1	0

# Load Combinations (2)

## Service LC: D + Lr

Active Design Criteria: User Minimum Design, Code Minimum Design, Service Design

Analysis: Linear

<i>Loading</i>	<i>Standard Factor</i>	<i>Alt. Envelope Factor</i>
Self-Dead Loading	1	1
Balance Loading	1	1
Other Dead Loading	1	1
Live (Roof) Loading	1	0

## Service LC: D + S

Active Design Criteria: User Minimum Design, Code Minimum Design, Service Design

Analysis: Linear

<i>Loading</i>	<i>Standard Factor</i>	<i>Alt. Envelope Factor</i>
Self-Dead Loading	1	1
Balance Loading	1	1
Other Dead Loading	1	1
Snow Loading	1	0

## Service LC: D + 0.75L + 0.75Lr

Active Design Criteria: User Minimum Design, Code Minimum Design, Service Design

Analysis: Linear

<i>Loading</i>	<i>Standard Factor</i>	<i>Alt. Envelope Factor</i>
Self-Dead Loading	1	1
Balance Loading	1	1
Other Dead Loading	1	1
Live (Reducible) Loading	0.75	0
Live (Unreducible) Loading	0.75	0
Live (Storage) Loading	0.75	0
Live (Parking) Loading	0.75	0
Live (Roof) Loading	0.75	0

# Load Combinations (3)

## Service LC: D + 0.75L + 0.75S

Active Design Criteria: User Minimum Design, Code Minimum Design, Service Design

Analysis: Linear

<i>Loading</i>	<i>Standard Factor</i>	<i>Alt. Envelope Factor</i>
Self-Dead Loading	1	1
Balance Loading	1	1
Other Dead Loading	1	1
Live (Reducible) Loading	0.75	0
Live (Unreducible) Loading	0.75	0
Live (Storage) Loading	0.75	0
Live (Parking) Loading	0.75	0
Snow Loading	0.75	0

## Sustained Service LC

Active Design Criteria: Sustained Service Design

Analysis: Linear

<i>Loading</i>	<i>Standard Factor</i>	<i>Alt. Envelope Factor</i>
Self-Dead Loading	1	1
Balance Loading	1	1
Other Dead Loading	1	1
Live (Reducible) Loading	0.5	0.5
Live (Unreducible) Loading	0.5	0.5
Live (Storage) Loading	1	1
Live (Parking) Loading	0.5	0.5
Live (Roof) Loading	0.5	0.5

## Factored LC: 1.4D

Active Design Criteria: User Minimum Design, Code Minimum Design, Strength Design, Ductility Design

Analysis: Linear

<i>Loading</i>	<i>Standard Factor</i>	<i>Alt. Envelope Factor</i>
Self-Dead Loading	1.4	0.9
Hyperstatic Loading	1	1
Other Dead Loading	1.4	0.9

# Load Combinations (4)

## Factored LC: 1.2D + 1.6L + 0.5Lr

Active Design Criteria: User Minimum Design, Code Minimum Design, Strength Design, Ductility Des

Analysis: Linear

<i>Loading</i>	<i>Standard Factor</i>	<i>Alt. Envelope Factor</i>
Self-Dead Loading	1.2	0.9
Hyperstatic Loading	1	1
Other Dead Loading	1.2	0.9
Live (Reducible) Loading	1.6	0
Live (Unreducible) Loading	1.6	0
Live (Storage) Loading	1.6	0
Live (Parking) Loading	1.6	0
Live (Roof) Loading	0.5	0

## Factored LC: 1.2D + f1L + 1.6Lr

Active Design Criteria: User Minimum Design, Code Minimum Design, Strength Design, Ductility Des

Analysis: Linear

<i>Loading</i>	<i>Standard Factor</i>	<i>Alt. Envelope Factor</i>
Self-Dead Loading	1.2	0.9
Hyperstatic Loading	1	1
Other Dead Loading	1.2	0.9
Live (Reducible) Loading	0.5	0
Live (Unreducible) Loading	1	0
Live (Storage) Loading	1	0
Live (Parking) Loading	1	0
Live (Roof) Loading	1.6	0

## Factored LC: 1.2D + 1.6L + 0.5S

Active Design Criteria: User Minimum Design, Code Minimum Design, Strength Design, Ductility Des

Analysis: Linear

<i>Loading</i>	<i>Standard Factor</i>	<i>Alt. Envelope Factor</i>
Self-Dead Loading	1.2	0.9
Hyperstatic Loading	1	1
Other Dead Loading	1.2	0.9
Live (Reducible) Loading	1.6	0
Live (Unreducible) Loading	1.6	0
Live (Storage) Loading	1.6	0
Live (Parking) Loading	1.6	0
Snow Loading	0.5	0

# Load Combinations (5)

## Factored LC: 1.2D + f1L + 1.6S

Active Design Criteria: User Minimum Design, Code Minimum Design, Strength Design, Ductility Des

Analysis: Linear

<i>Loading</i>	<i>Standard Factor</i>	<i>Alt. Envelope Factor</i>
Self-Dead Loading	1.2	0.9
Hyperstatic Loading	1	1
Other Dead Loading	1.2	0.9
Live (Reducible) Loading	0.5	0
Live (Unreducible) Loading	1	0
Live (Storage) Loading	1	0
Live (Parking) Loading	1	0
Snow Loading	1.6	0

# Mesh Input: Standard Plan

Mesh Input: Beams; Beam Priorities; Slab Area Priorities; Slab Openings; Slab Opening Priorities; Point Supports; Point Support  
Drawing Import: User Notes; User Lines; User Dimensions; S-CONC; S-GRIDS; Defpoints; S-SLABEDGE; S-CONC-ABOVE;  
Scale = 1:70

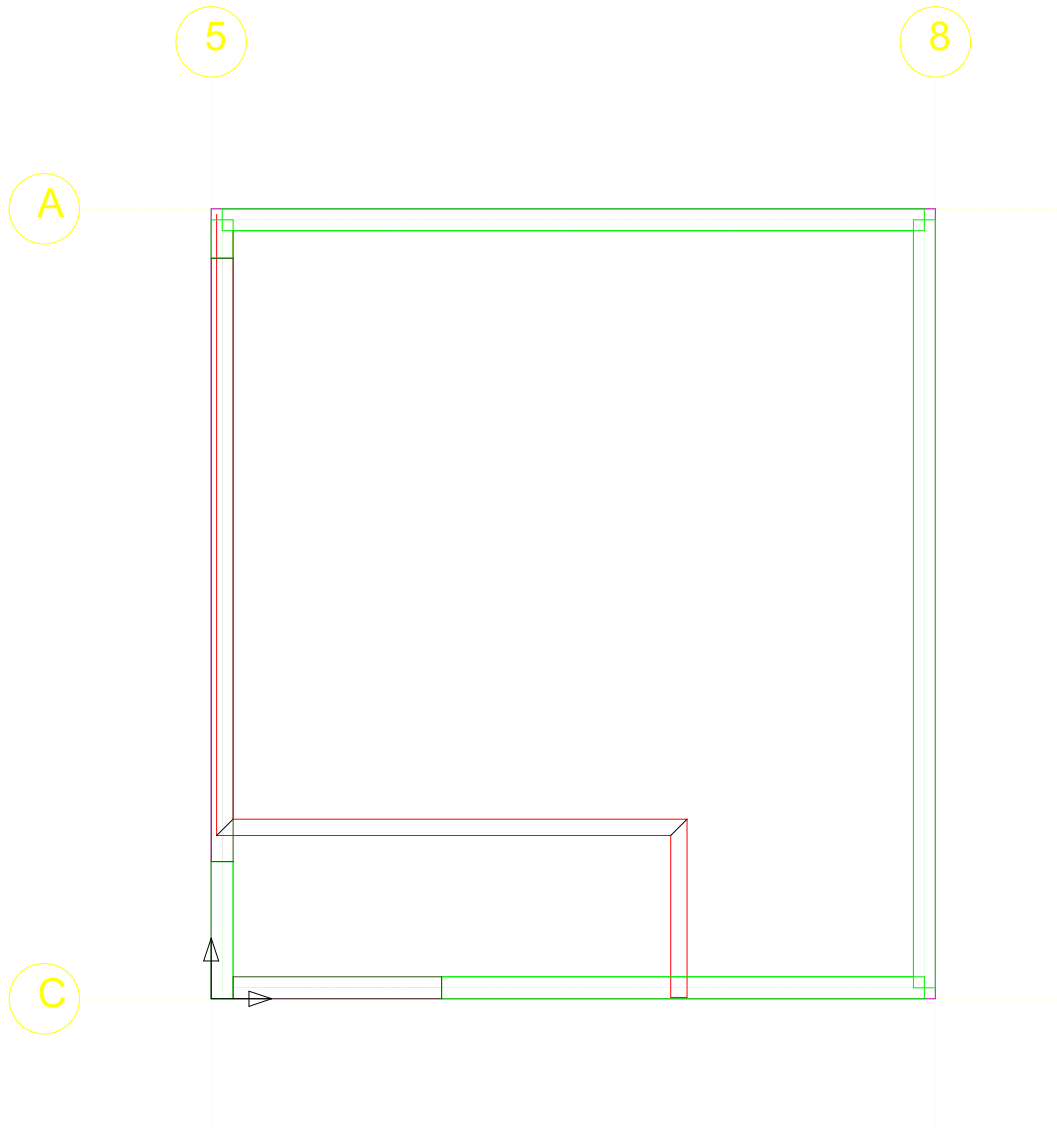

# Element: Standard Plan

Element: User Lines; User Notes; User Dimensions; Wall Elements Below; Wall Elements Above; Column Elements Below; Column Elements Above;  
Drawing Import: User Lines; User Notes; User Dimensions;  
Scale = 1:70

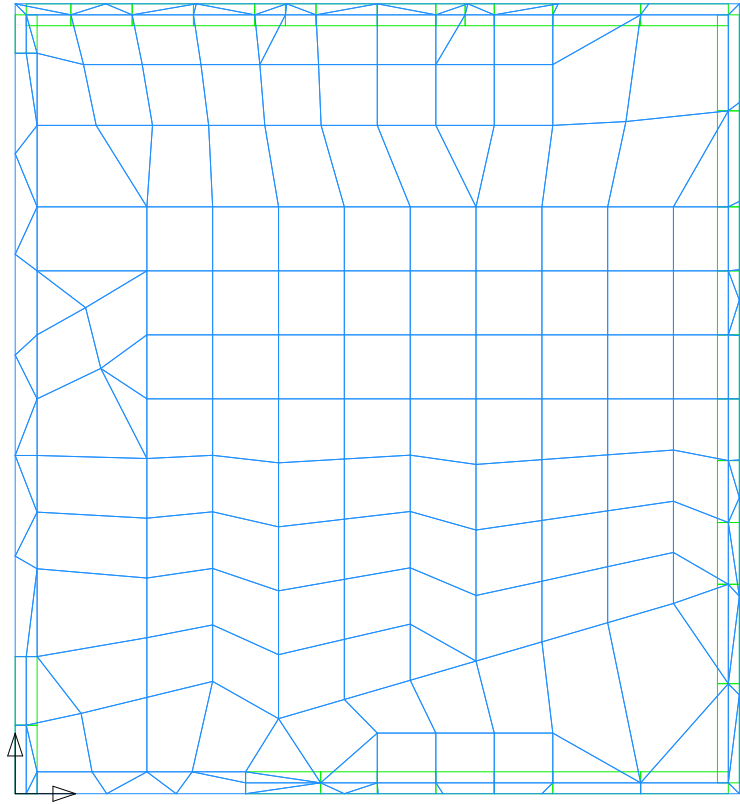

# Element: Slab Summary Plan

Element: User Lines; User Notes; User Dimensions; Wall Elements Below; Wall Elements Above; Column Elements Below; Column Elements Above  
Drawing Import: User Lines; User Notes; User Dimensions;  
Scale = 1:70

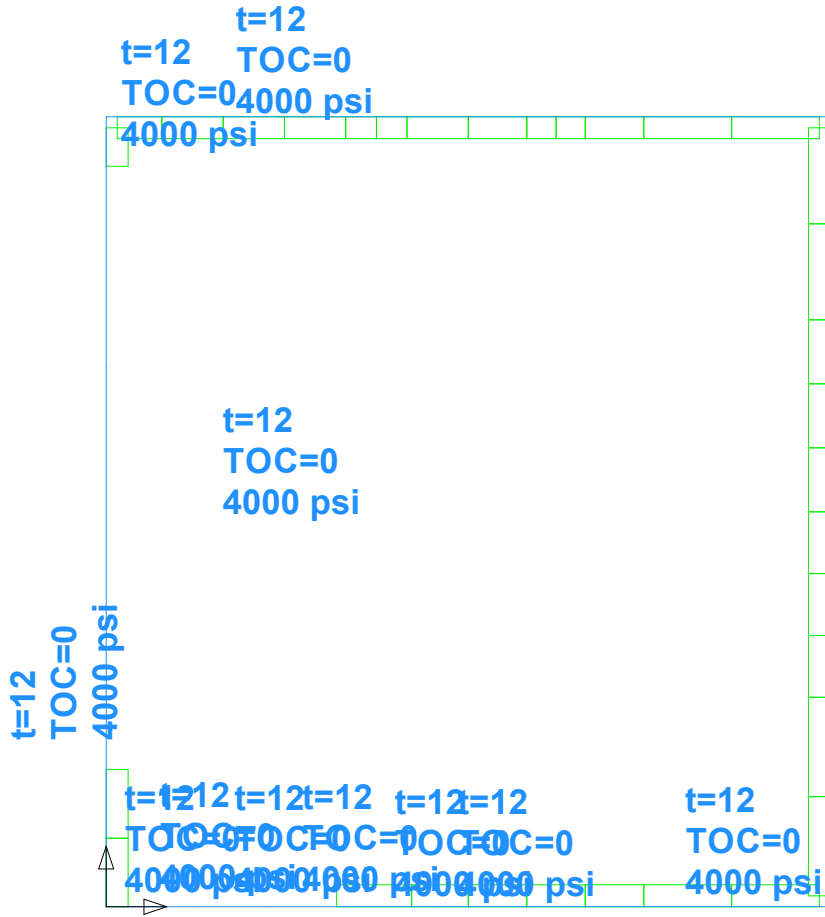



# Element: Structure Summary Perspective

Wall Elements Below; Wall Elements Above; Column Elements Below; Column Elements Above; Slab Elements;  
User Lines; User Notes; User Dimensions;

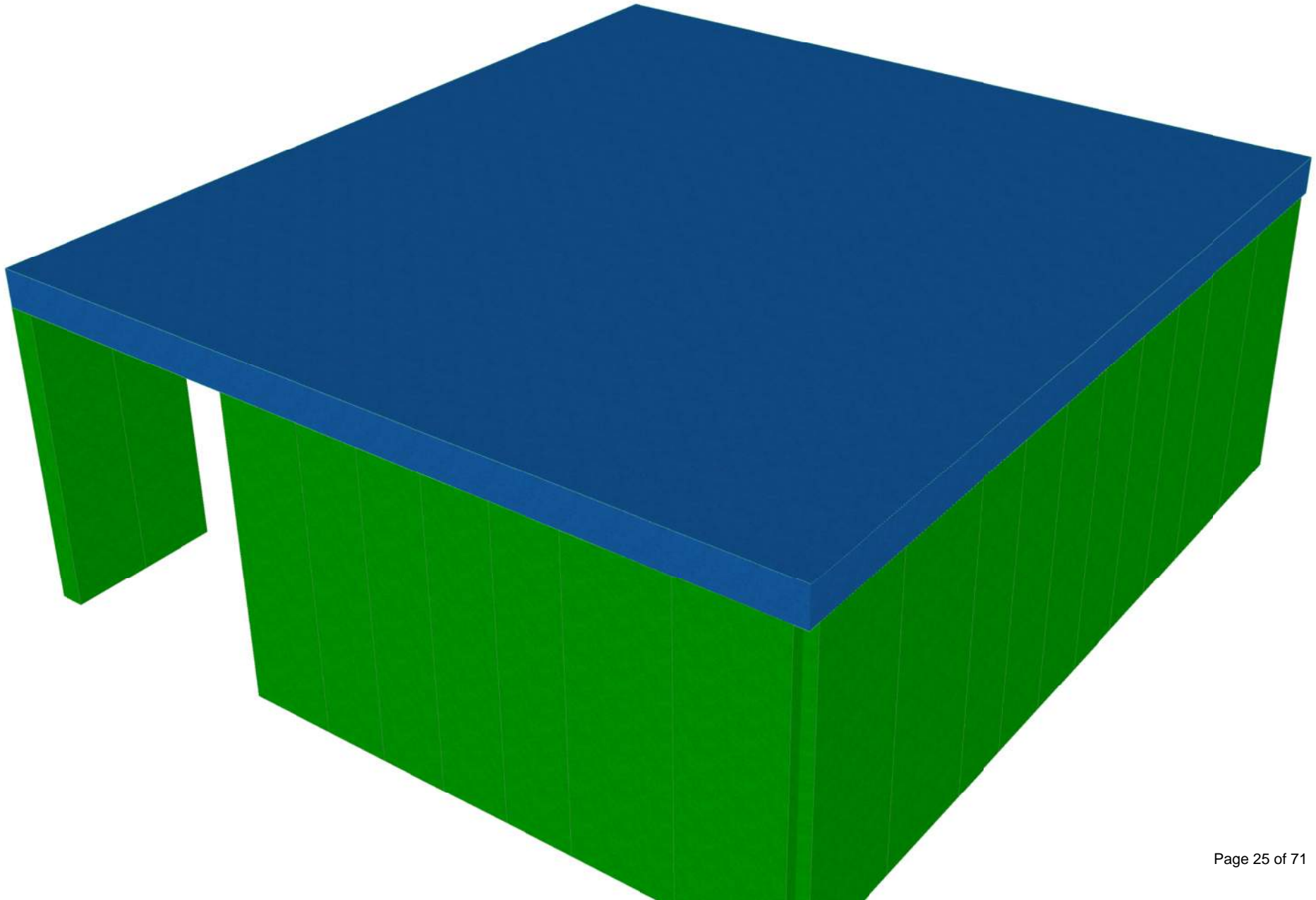

# Self-Dead Loading: Std Reactions Plan

Self-Dead Loading: User Lines; User Notes; User Dimensions; Point Loads; Point Load Values; Point Load Icons; Line Loads; Line Load Values; Line Load Icons;

Drawing Import: User Lines; User Notes; User Dimensions;

Element: Wall Elements Below; Wall Elements Above; Wall Element Outline Only; Column Elements Below; Column Elements Above;

Scale = 1:70

Self-Dead Loading - Reaction Plot: (Wall Below,Column Below,Point Spring,Line Spring,Point Support,Line Support)(Fr,Fs,Fz,Mr,Ms,Mz)

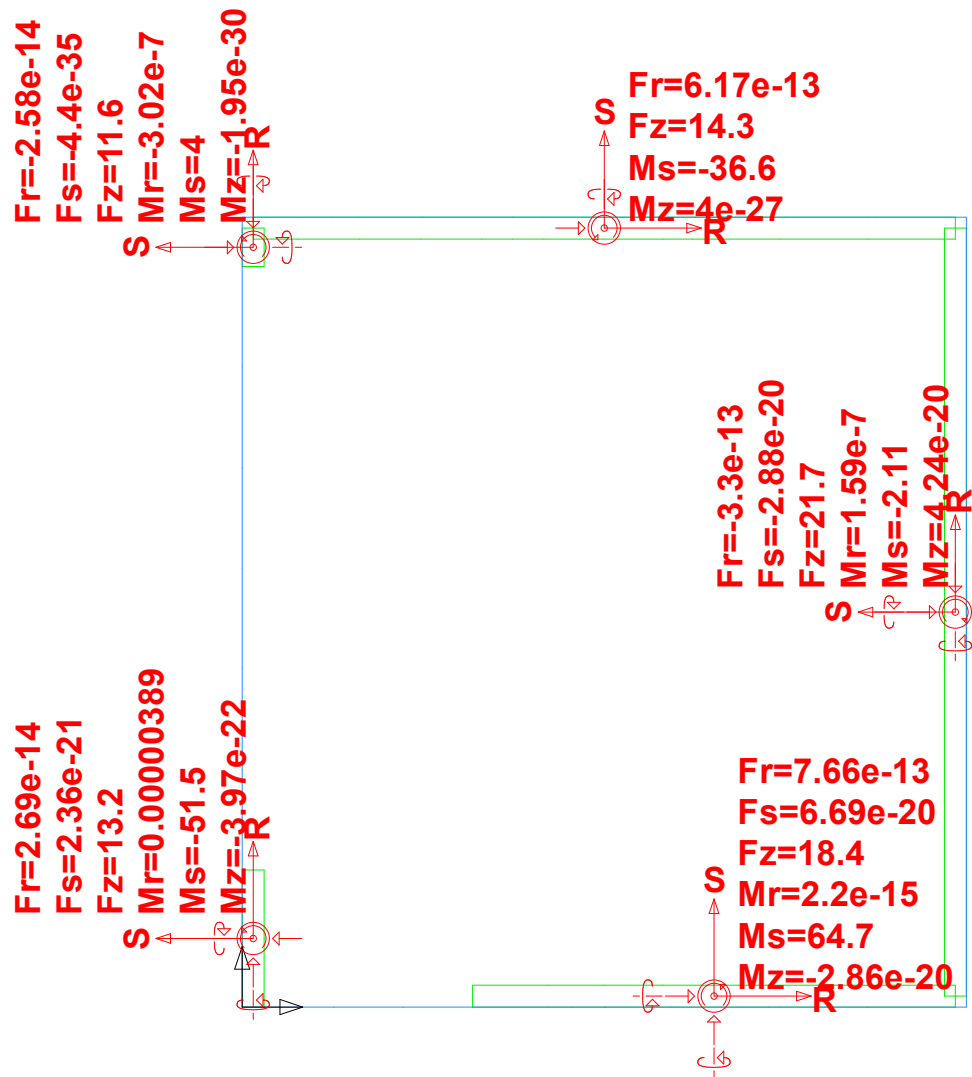

# Self-Dead Loading: Std Reactions Plan (2)

# Live (Unreducible) Loading: All Loads Plan

Live (Unreducible) Loading: Point Loads; Point Load Icons; Point Load Values; Line Loads; Line Load Icons; Line Load Values  
 Drawing Import: User Notes; User Lines; User Dimensions; Defpoints;  
 Element: Wall Elements Above; Wall Elements Below; Wall Element Outline Only; Column Elements Above; Column Elements Below  
 Scale = 1:70

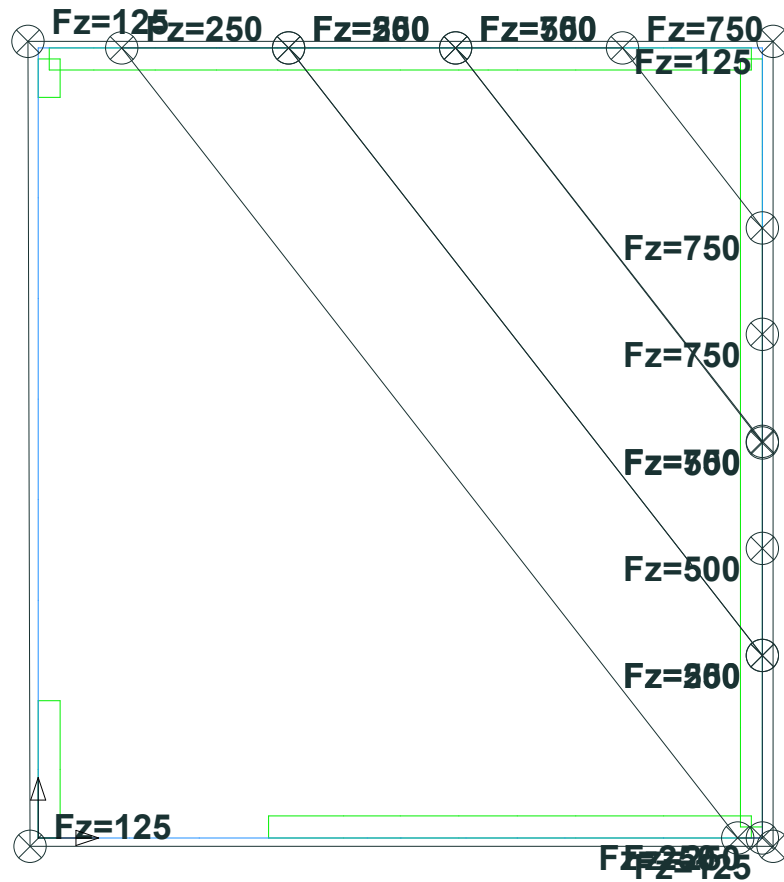

# Live (Unreducible) Loading: Std Reactions Plan

Live (Unreducible) Loading: User Lines; User Notes; User Dimensions; Point Loads; Point Load Values; Point Load Icons; Line  
 Drawing Import: User Lines; User Notes; User Dimensions;  
 Element: Wall Elements Below; Wall Elements Above; Wall Element Outline Only; Column Elements Below; Column Elements A  
 Scale = 1:70

Live (Unreducible) Loading - Reaction Plot: (Wall Below,Column Below,Point Spring,Line Spring,Point Support,Line Support)(F

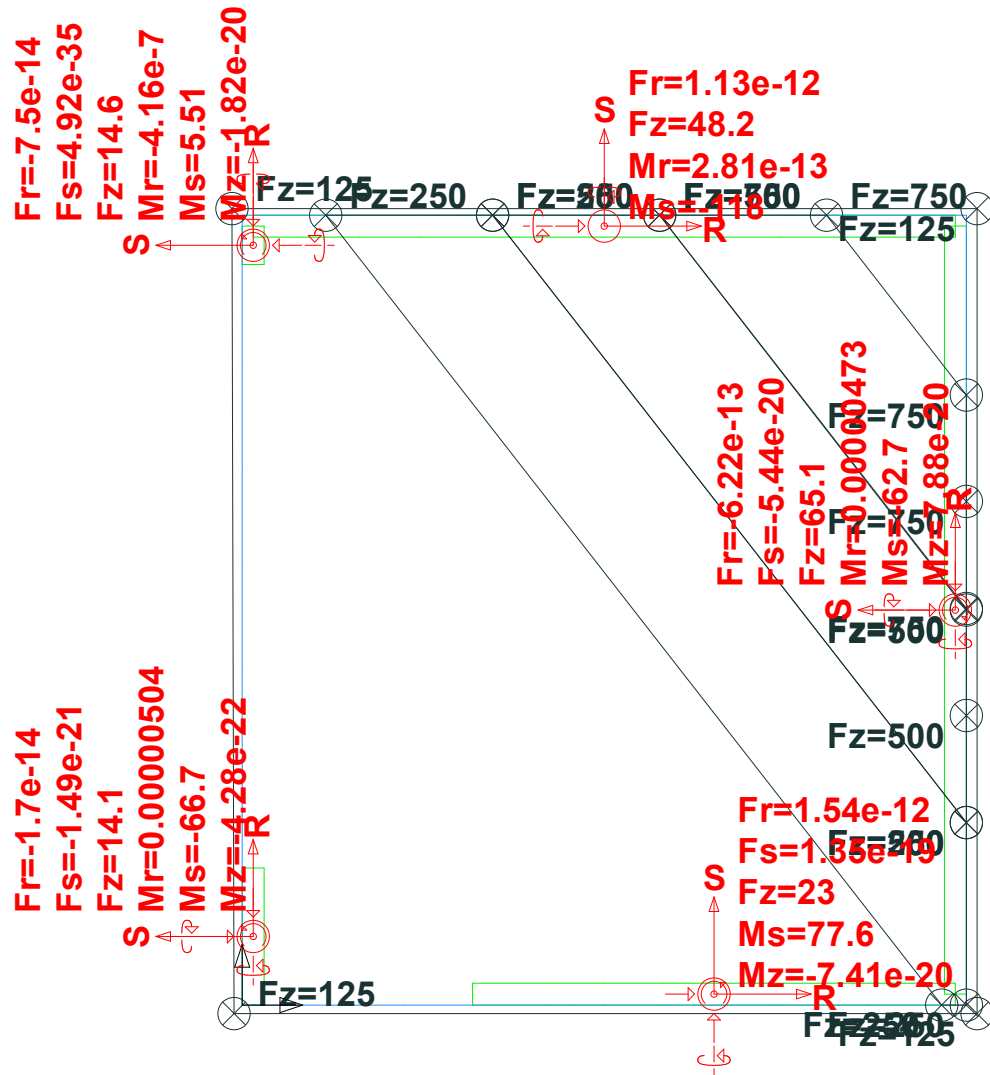

# Live (Unreducible) Loading: Std Reactions Plan (2)

# Live (Roof) Loading: All Loads Plan

Live (Roof) Loading: User Lines; User Notes; User Dimensions; Point Loads; Point Load Icons; Point Load Values; Line Loads;  
Drawing Import: User Lines; User Notes; User Dimensions;  
Element: Wall Elements Below; Wall Elements Above; Wall Element Outline Only; Column Elements Below; Column Elements A  
Scale = 1:70

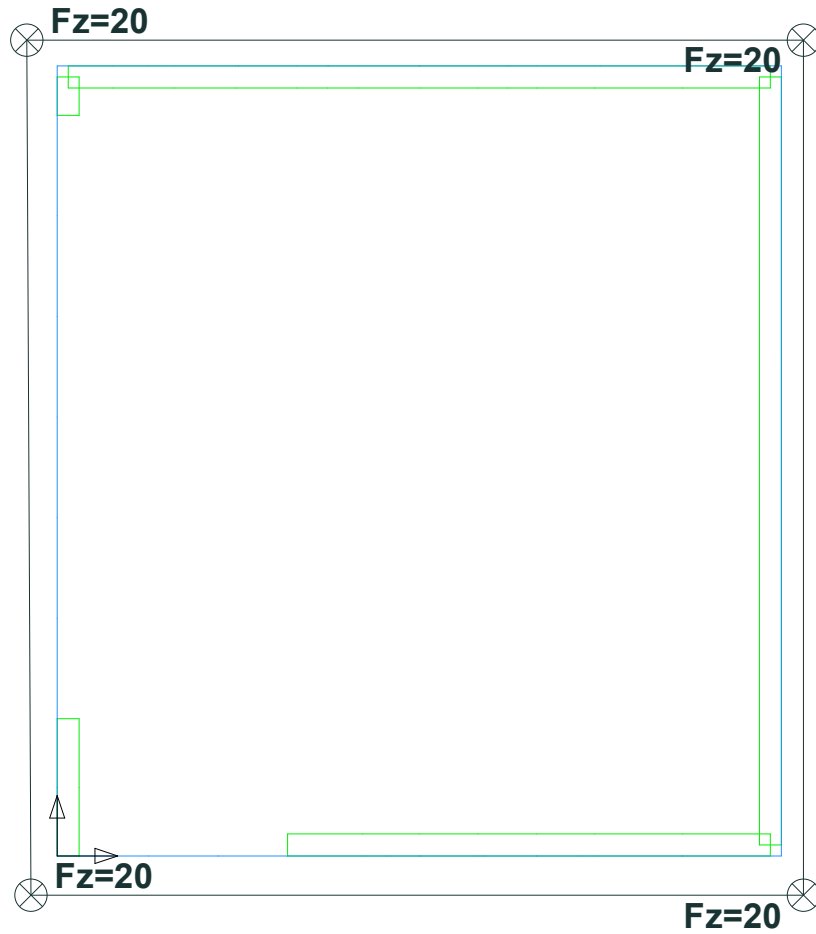

# Snow Loading: All Loads Plan

Snow Loading: Point Loads; Point Load Icons; Point Load Values; Line Loads; Line Load Icons; Line Load Values; Area Loads  
Drawing Import: User Notes; User Lines; User Dimensions; S-GRIDS;  
Element: Wall Elements Above; Wall Elements Below; Wall Element Outline Only; Column Elements Above; Column Elements Below  
Scale = 1:70

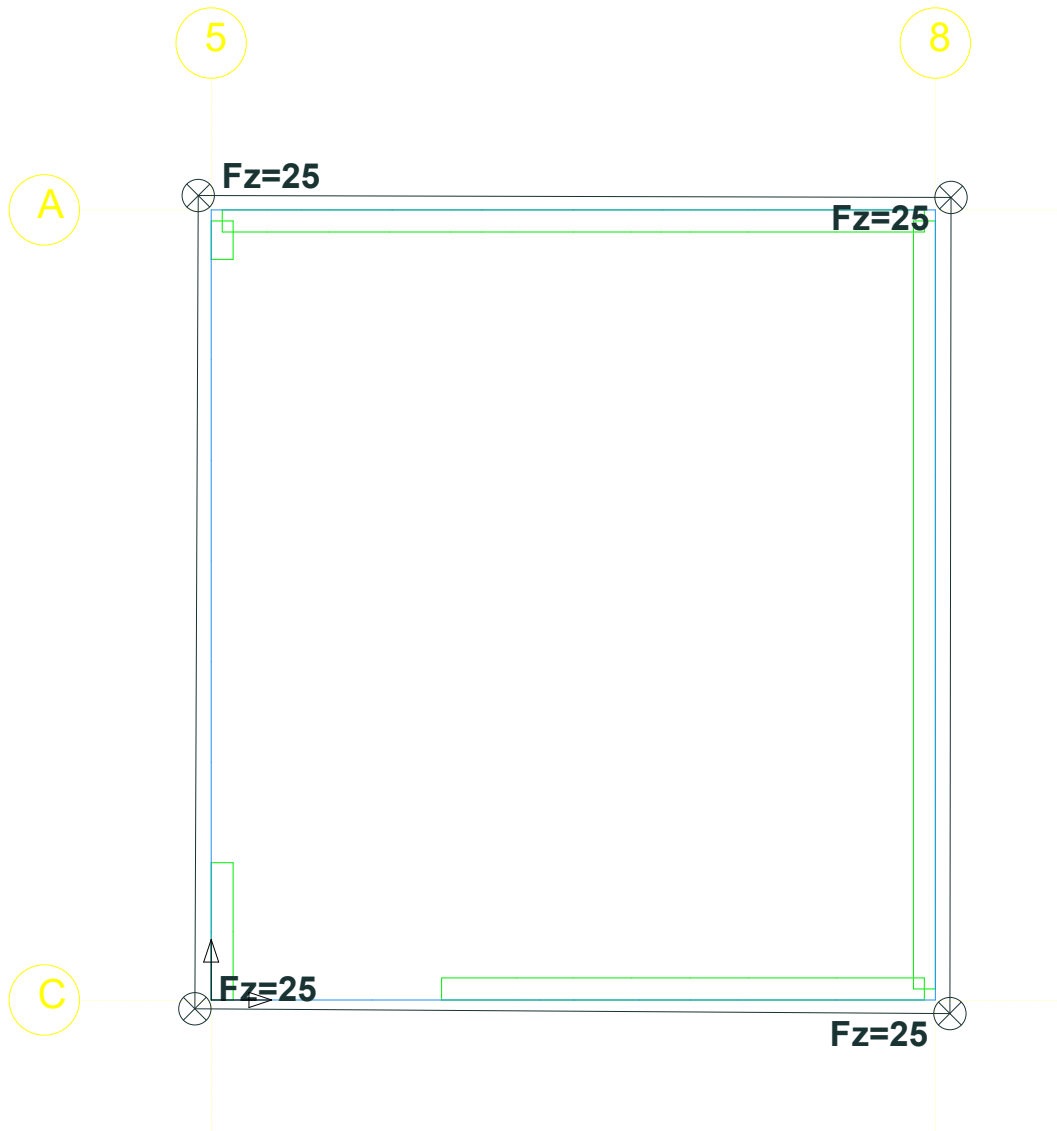



# Sustained Service LC: Max Deflection Plan

Sustained Service LC: User Lines; User Notes; User Dimensions;

Drawing Import: User Lines; User Notes; User Dimensions;

Element: Wall Elements Below; Wall Elements Above; Wall Element Outline Only; Column Elements Below; Column Elements A

Scale = 1:70

Sustained Service LC - Vertical Deflection Plot (Maximum Values)



Min Value = -0.009395 inches @ (0,24)    Max Value = 0.1126 inches @ (8,12)

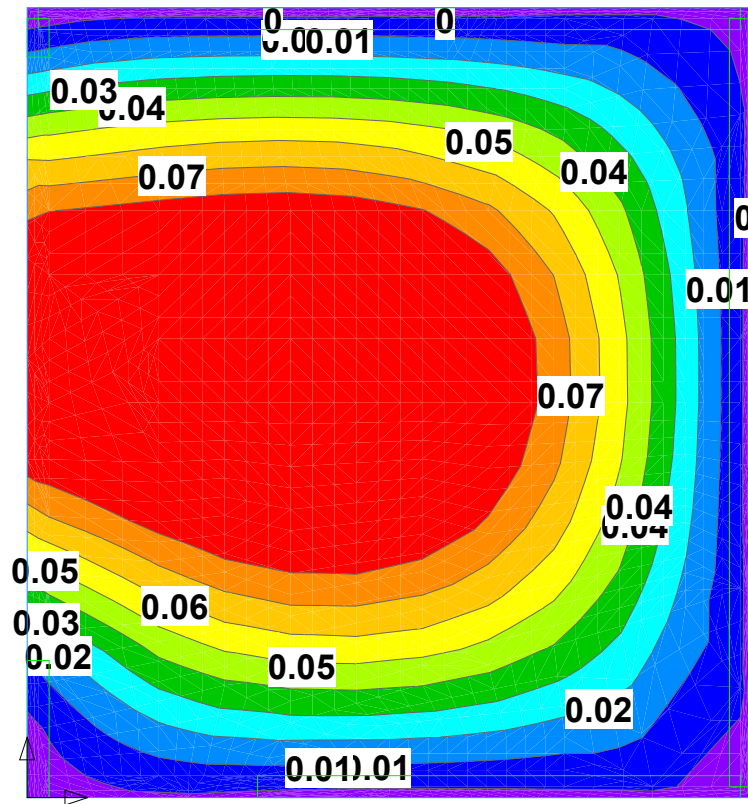

# Sustained Service LC: Max Deflection Plan (2)

# Factored LC: 1.2D + 1.6L + 0.5Lr: Max Mx Plan

Factored LC: 1.2D + 1.6L + 0.5Lr: User Lines; User Notes; User Dimensions;

Drawing Import: User Lines; User Notes; User Dimensions;

Element: Wall Elements Below; Wall Elements Above; Wall Element Outline Only; Column Elements Below; Column Elements A

Scale = 1:70

Factored LC: 1.2D + 1.6L + 0.5Lr - Bending Moment Plot (Maximum Values) (X-Axis Direction)

One Contour = 0.5 Kips

Min Value = -5.899 Kips @ (0,3.125) Max Value = 20.52 Kips @ (0,14.86)

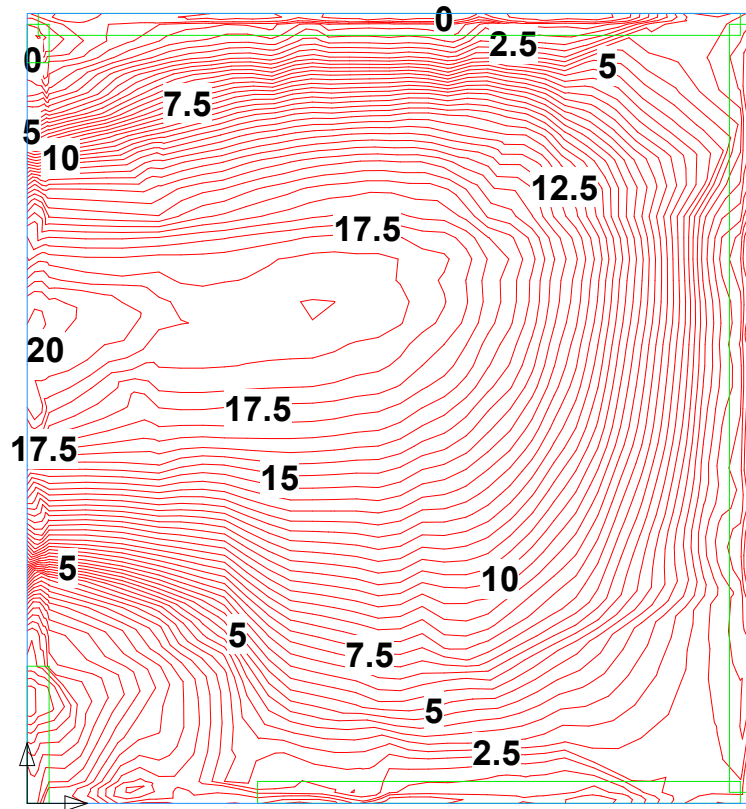

# Factored LC: 1.2D + 1.6L + 0.5Lr: Max Mx Plan (2)

# Factored LC: 1.2D + 1.6L + 0.5Lr: Min Mx Plan

Factored LC: 1.2D + 1.6L + 0.5Lr: User Lines; User Notes; User Dimensions;

Drawing Import: User Lines; User Notes; User Dimensions;

Element: Wall Elements Below; Wall Elements Above; Wall Element Outline Only; Column Elements Below; Column Elements A

Scale = 1:70

Factored LC: 1.2D + 1.6L + 0.5Lr - Bending Moment Plot (Minimum Values) (X-Axis Direction)

One Contour = 0.5 Kips

Min Value = -21.46 Kips @ (0,3.125) Max Value = 5.4 Kips @ (0,14.86)

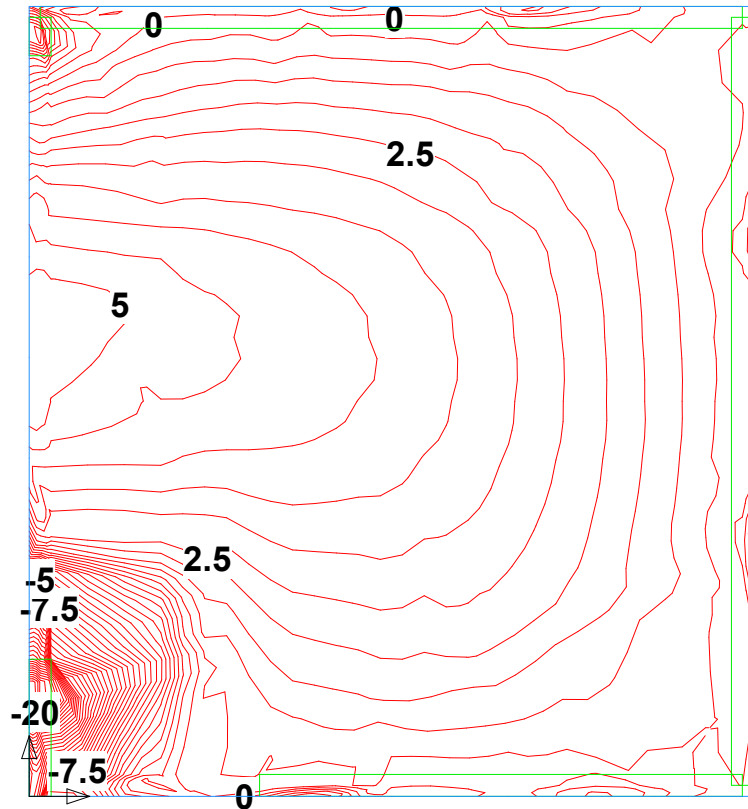

# Factored LC: 1.2D + 1.6L + 0.5Lr: Min Mx Plan (2)

# Factored LC: 1.2D + 1.6L + 0.5Lr: Max My Plan

Factored LC: 1.2D + 1.6L + 0.5Lr: User Lines; User Notes; User Dimensions;

Drawing Import: User Lines; User Notes; User Dimensions;

Element: Wall Elements Below; Wall Elements Above; Wall Element Outline Only; Column Elements Below; Column Elements A

Scale = 1:70

Factored LC: 1.2D + 1.6L + 0.5Lr - Bending Moment Plot (Maximum Values) (Y-Axis Direction)

One Contour = 0.5 Kips

Min Value = -0.6659 Kips @ (22,7.5) Max Value = 15.48 Kips @ (15,13.94)

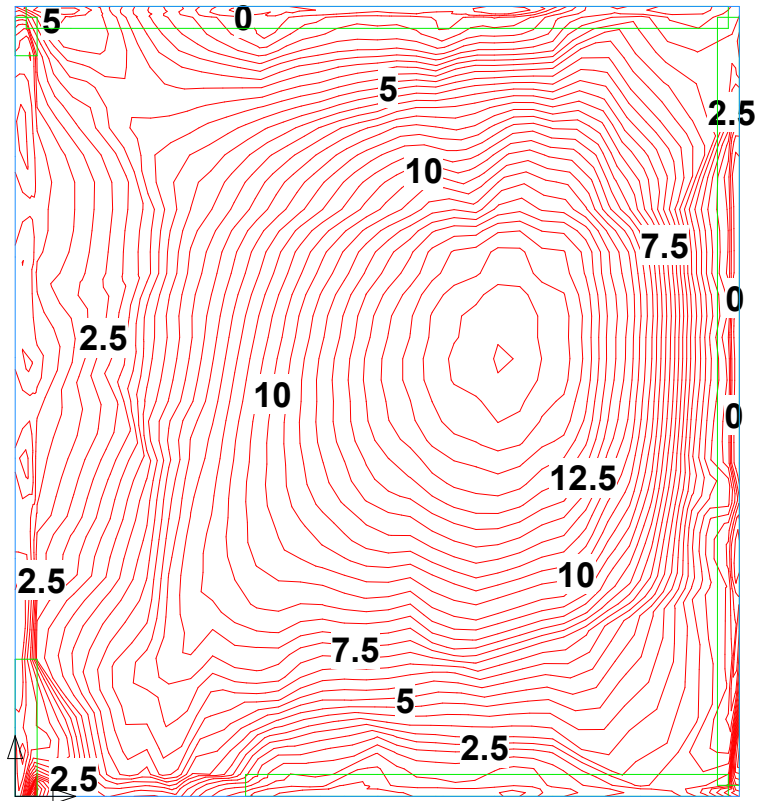

# Factored LC: 1.2D + 1.6L + 0.5Lr: Max My Plan (2)



# Factored LC: 1.2D + 1.6L + 0.5Lr: Min My Plan

Factored LC: 1.2D + 1.6L + 0.5Lr: User Lines; User Notes; User Dimensions;

Drawing Import: User Lines; User Notes; User Dimensions;

Element: Wall Elements Below; Wall Elements Above; Wall Element Outline Only; Column Elements Below; Column Elements A

Scale = 1:70

Factored LC: 1.2D + 1.6L + 0.5Lr - Bending Moment Plot (Minimum Values) (Y-Axis Direction)

One Contour = 0.1 Kips

Min Value = -2.77 Kips @ (22,7.5) Max Value = 2.808 Kips @ (11,10.23)

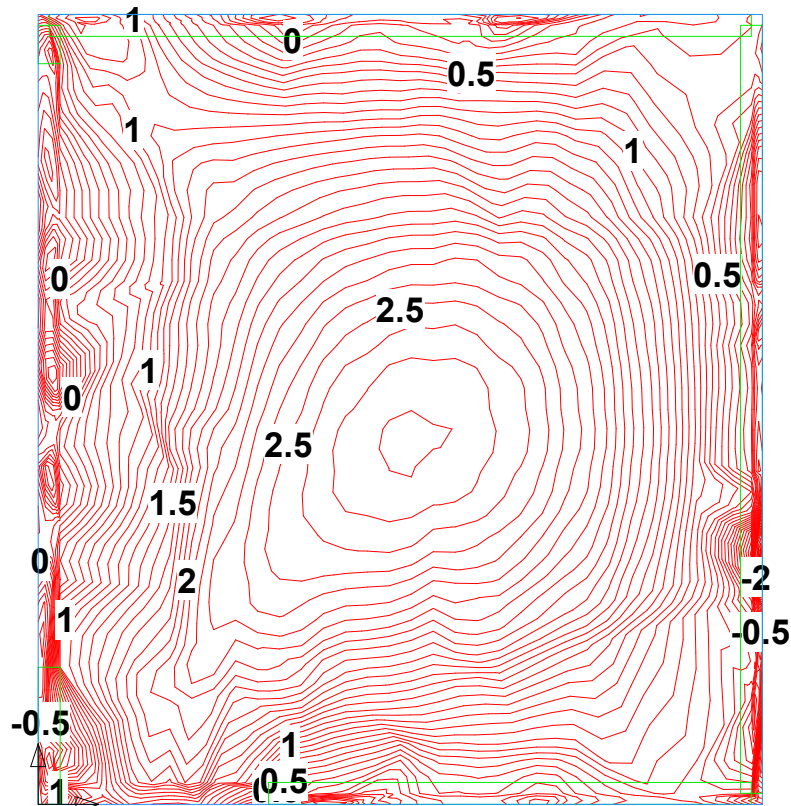

# Factored LC: 1.2D + 1.6L + 0.5Lr: Min My Plan (2)

# Factored LC: 1.2D + 1.6L + 0.5Lr: Std Reactions Plan

Factored LC: 1.2D + 1.6L + 0.5Lr: User Lines; User Notes; User Dimensions;

Drawing Import: User Lines; User Notes; User Dimensions;

Element: Wall Elements Below; Wall Elements Above; Wall Element Outline Only; Column Elements Below; Column Elements Above

Scale = 1:70

Factored LC: 1.2D + 1.6L + 0.5Lr - Reaction Plot: (Wall Below,Column Below,Point Spring,Line Spring,Point Support,Line Support)

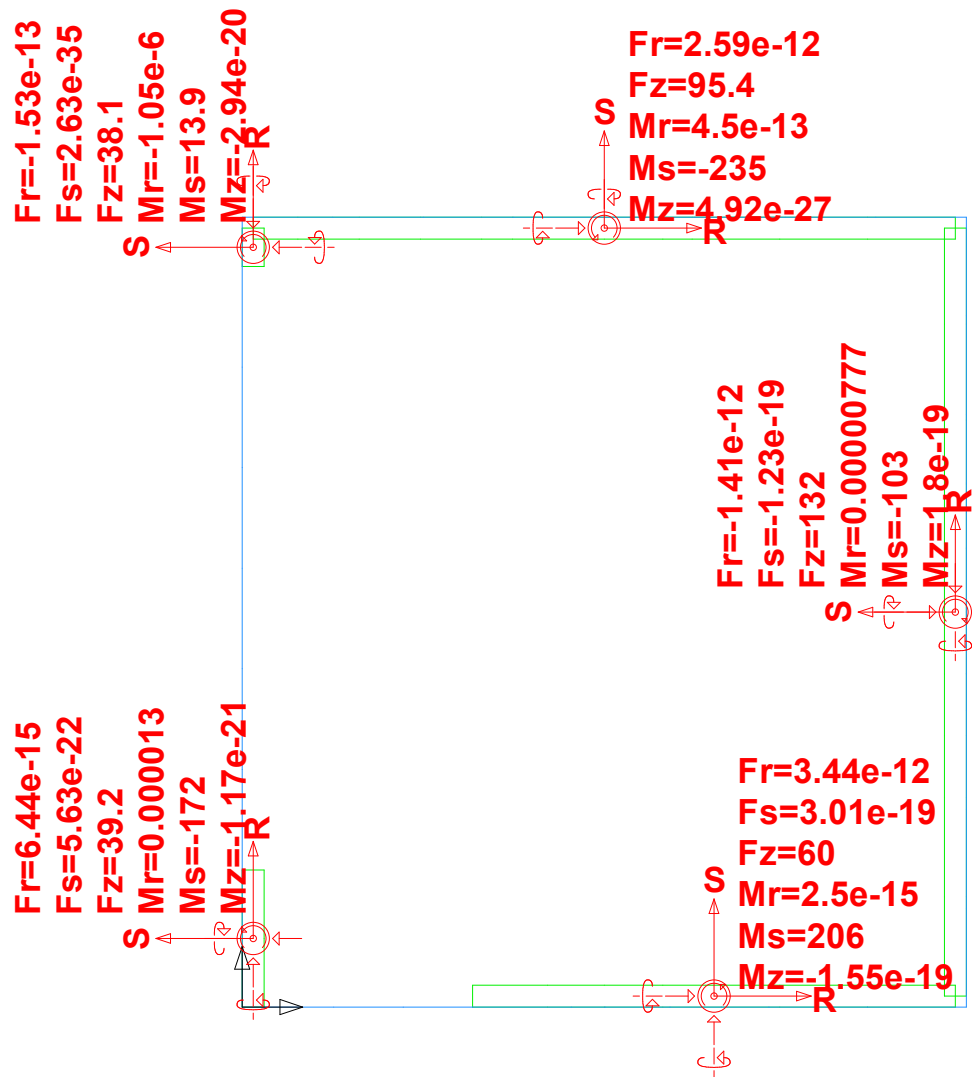

# Factored LC: 1.2D + 1.6L + 0.5Lr: Std Reactions Plan (2)

# Design Strip: Latitude Design Spans Plan

Design Strip: Latitude Span Boundaries; Latitude SSSs; Latitude DSs; DS Numbers; Latitude Strip Boundaries; Latitude SSSs; S  
Drawing Import: User Notes; User Lines; User Dimensions; S-GRIDS;  
Mesh Input: Beams;  
Element: Wall Elements Above; Wall Elements Below; Wall Element Outline Only; Column Elements Above; Column Elements B  
Scale = 1:70

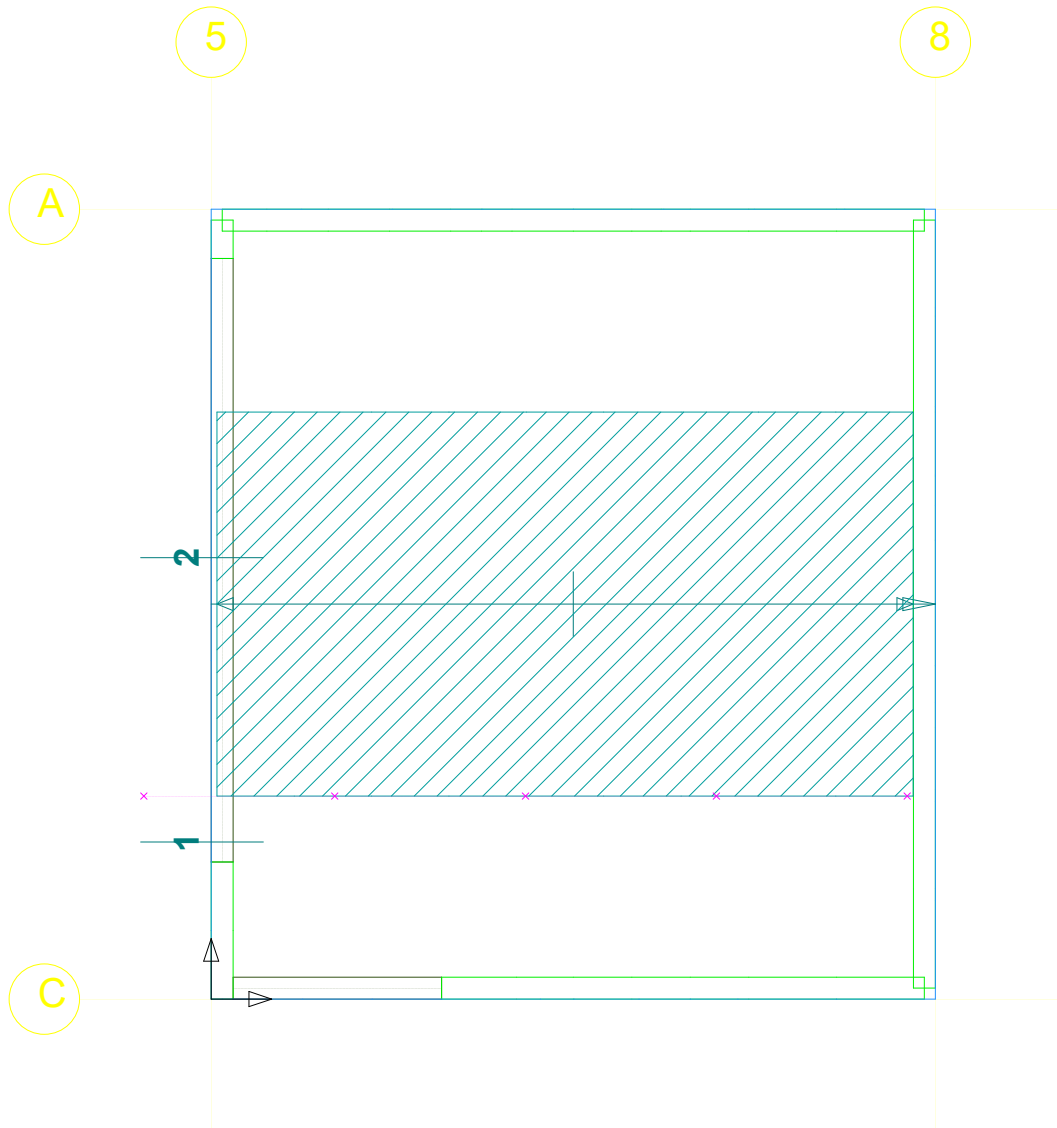

# Design Strip: Latitude Design Spans Plan (2)

# Design Strip: Longitude Design Spans Plan

Design Strip: Longitude Span Boundaries; Longitude SSSs; Longitude DSs; Longitude Strip Boundaries; Longitude SSSs; SSS  
Drawing Import: User Notes; User Lines; User Dimensions; S-GRIDS;  
Element: Wall Elements Above; Wall Elements Below; Wall Element Outline Only; Column Elements Above; Column Elements Below  
Scale = 1:70

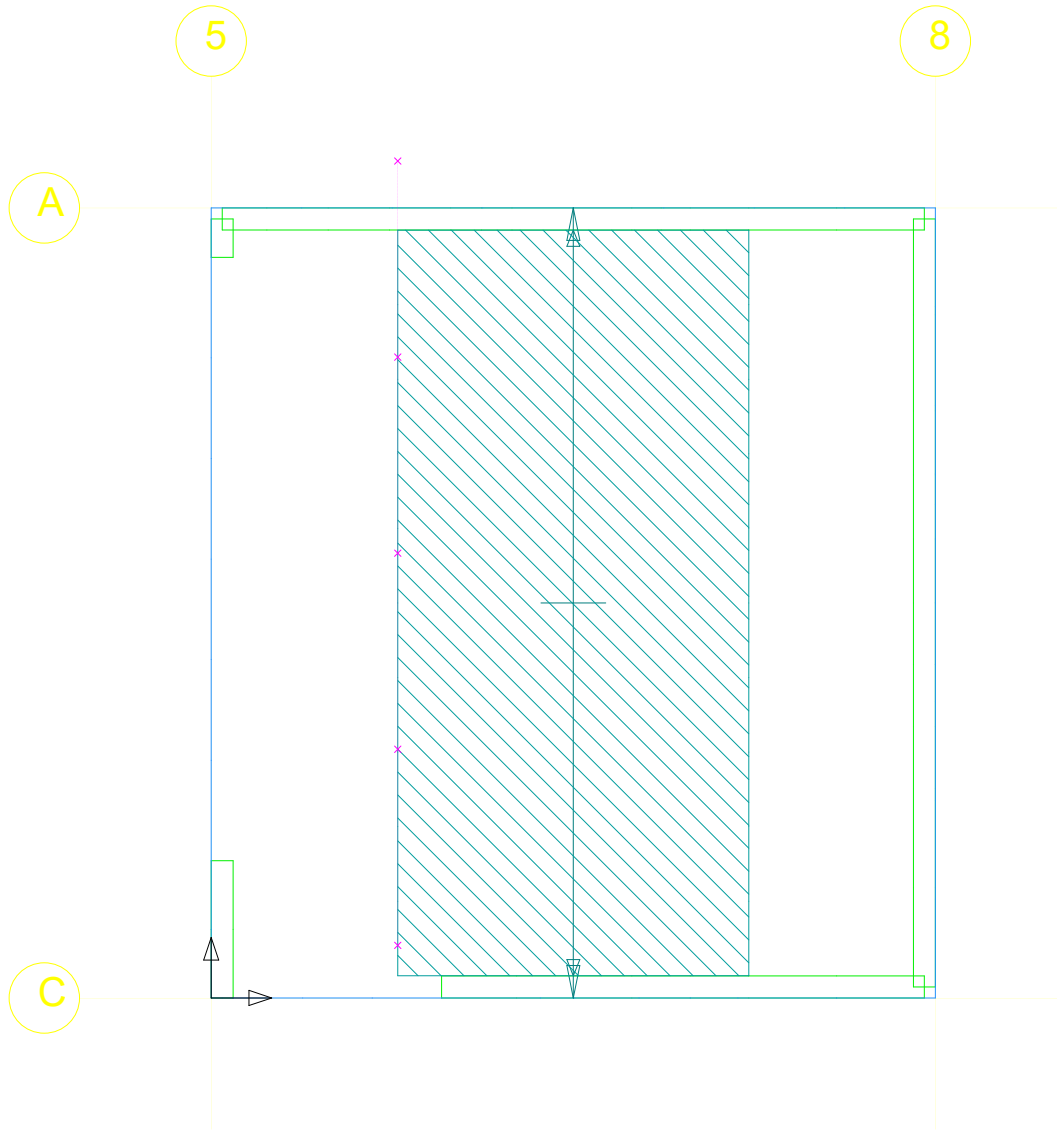

# Reinforcement: Top Bars Plan

Reinforcement: User Lines; User Notes; User Dimensions; Latitude User Concentrated Reinf.; Latitude Program Concentrated Reinf.  
Drawing Import: User Lines; User Notes; User Dimensions;  
Element: Wall Elements Below; Wall Elements Above; Wall Element Outline Only; Column Elements Below; Column Elements Above  
Scale = 1:70

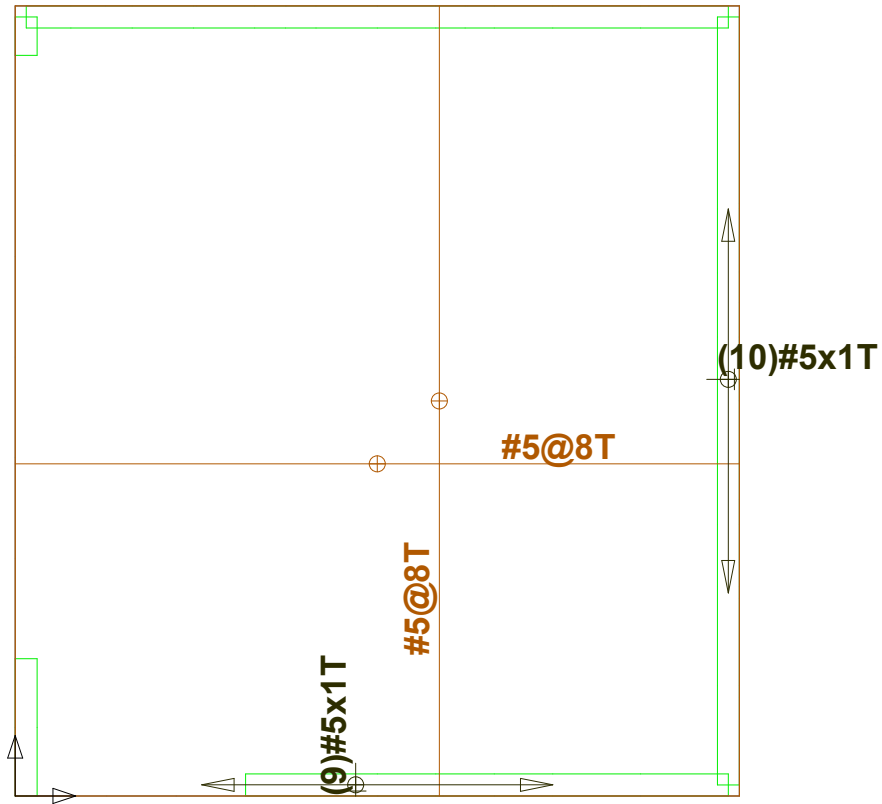



# Reinforcement: Bottom Bars Plan

Reinforcement: User Lines; User Notes; User Dimensions; Latitude User Concentrated Reinf.; Latitude Program Concentrated Reinf.  
Drawing Import: User Lines; User Notes; User Dimensions;  
Element: Wall Elements Below; Wall Elements Above; Wall Element Outline Only; Column Elements Below; Column Elements Above  
Scale = 1:70

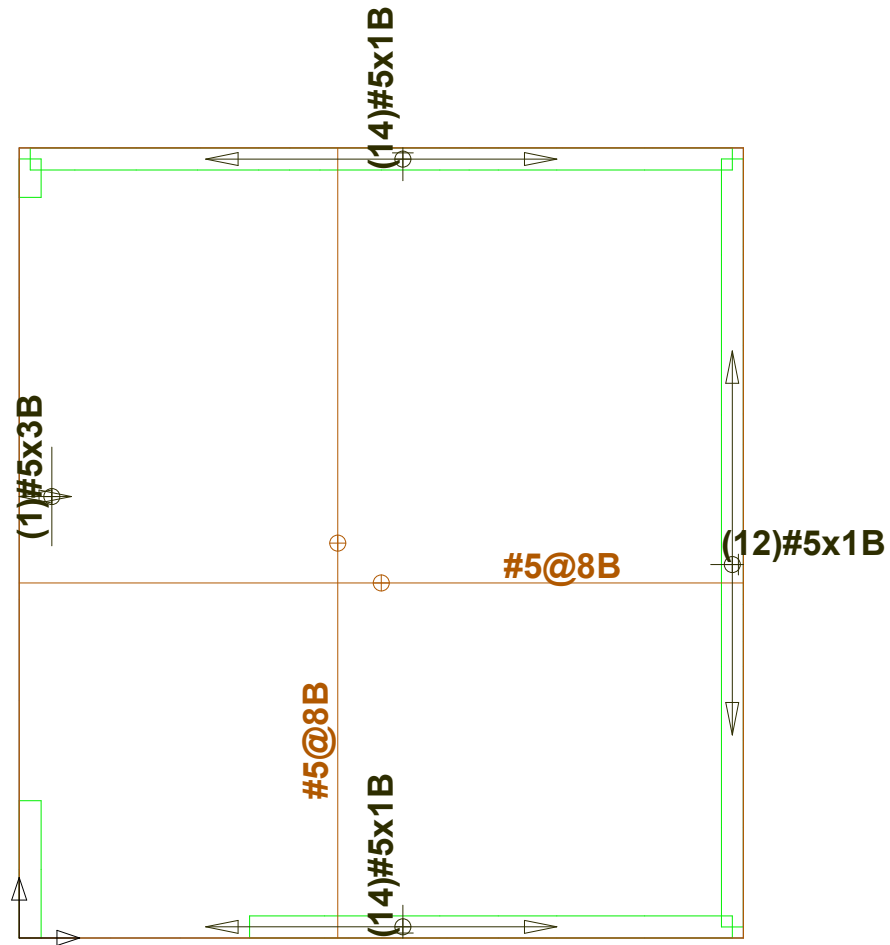

# Reinforcement: Individual Top Bars Plan

Reinforcement: User Lines; User Notes; User Dimensions; Longitude User Individual Bars; Longitude Program Individual Bars;  
Drawing Import: User Lines; User Notes; User Dimensions;  
Element: Wall Elements Below; Wall Elements Above; Wall Element Outline Only; Column Elements Below; Column Elements A  
Scale = 1:70

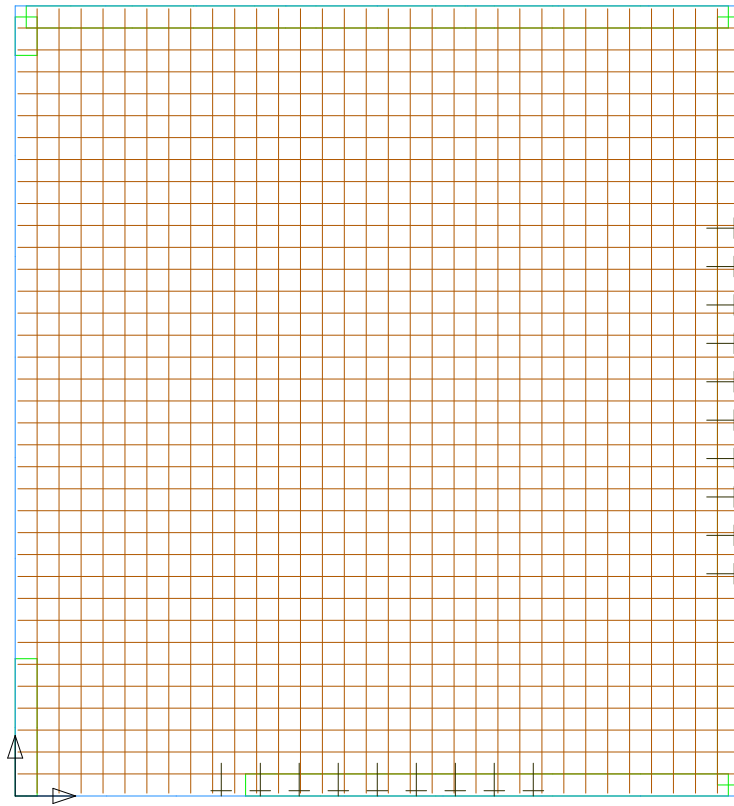

# Reinforcement: Individual Bottom Bars Plan

Reinforcement: User Lines; User Notes; User Dimensions; Longitude User Individual Bars; Longitude Program Individual Bars;  
Drawing Import: User Lines; User Notes; User Dimensions;  
Element: Wall Elements Below; Wall Elements Above; Wall Element Outline Only; Column Elements Below; Column Elements A  
Scale = 1:70

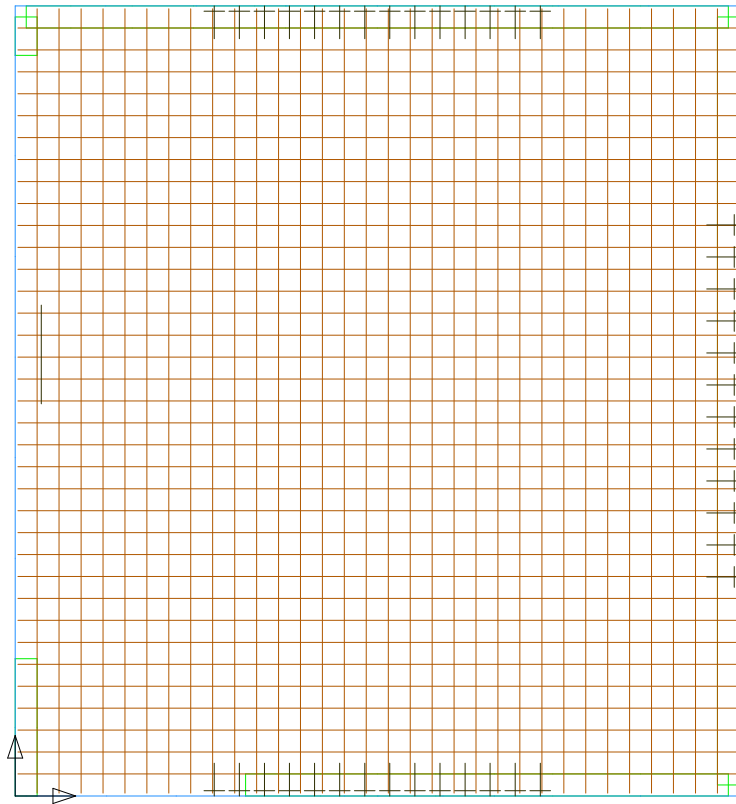

# Reinforcement: Detailed Bars & SSR Perspective

Latitude User Individual Bars; Longitude User Individual Bars; Latitude Program Individual Bars; Longitude Program Individual Bars; User Lines; User Notes; User Dimensions; Wall Elements Below; Column Elements Below; Slab Elements; Slab Elements Soffit Only; Tendons; Jacks; Tendons; Jacks; Tendons; Jacks; Tendons; Jacks;

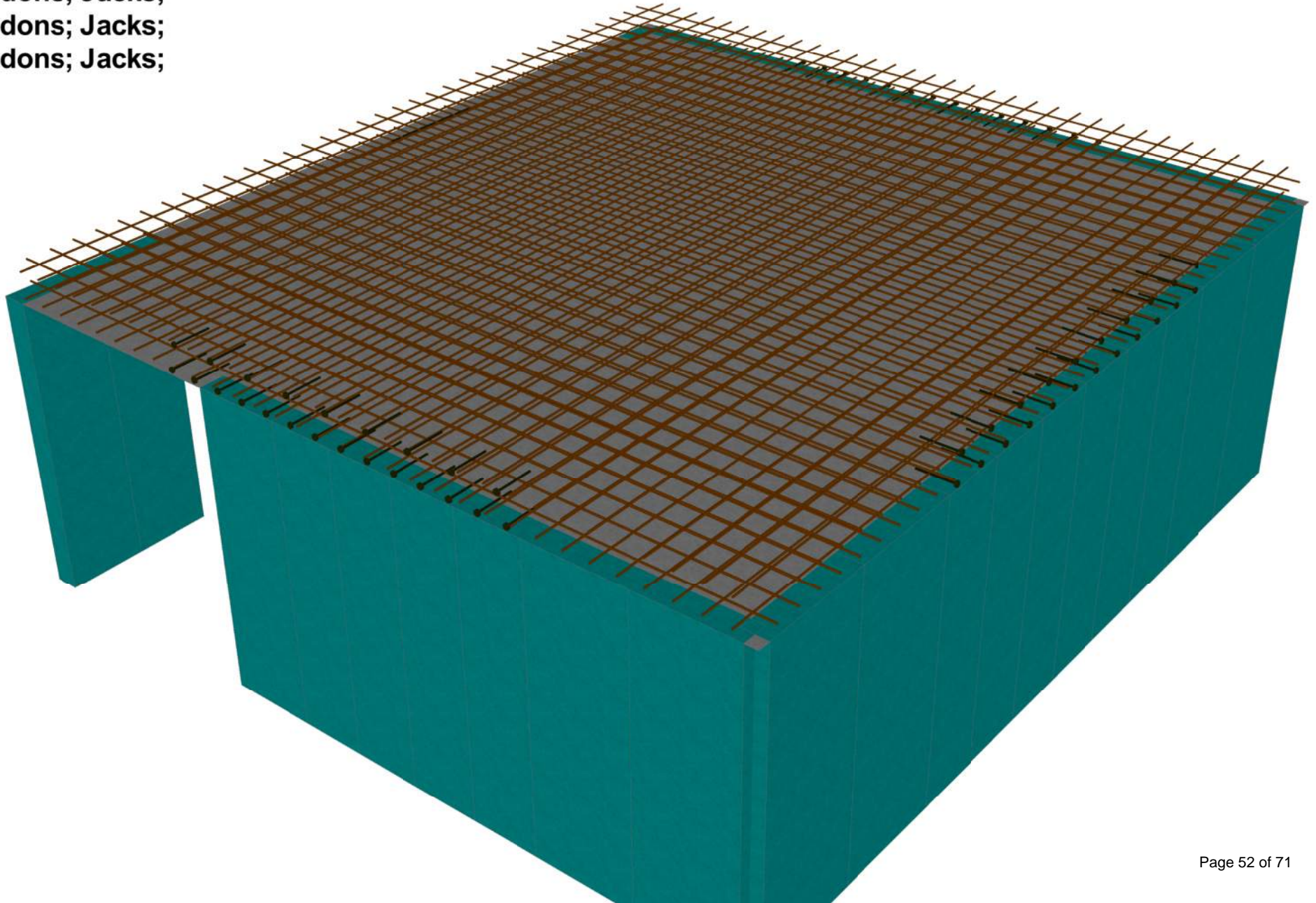



# Reinforcement: Transparent Slab Perspective

Latitude User Individual Bars; Longitude User Individual Bars; Latitude Program Individual Bars; Longitude Program Individual Bars;  
User Lines; User Notes; User Dimensions;  
Wall Elements Below; Column Elements Below; Slab Elements;  
Tendons; Jacks;  
Tendons; Jacks;  
Tendons; Jacks;  
Tendons; Jacks;

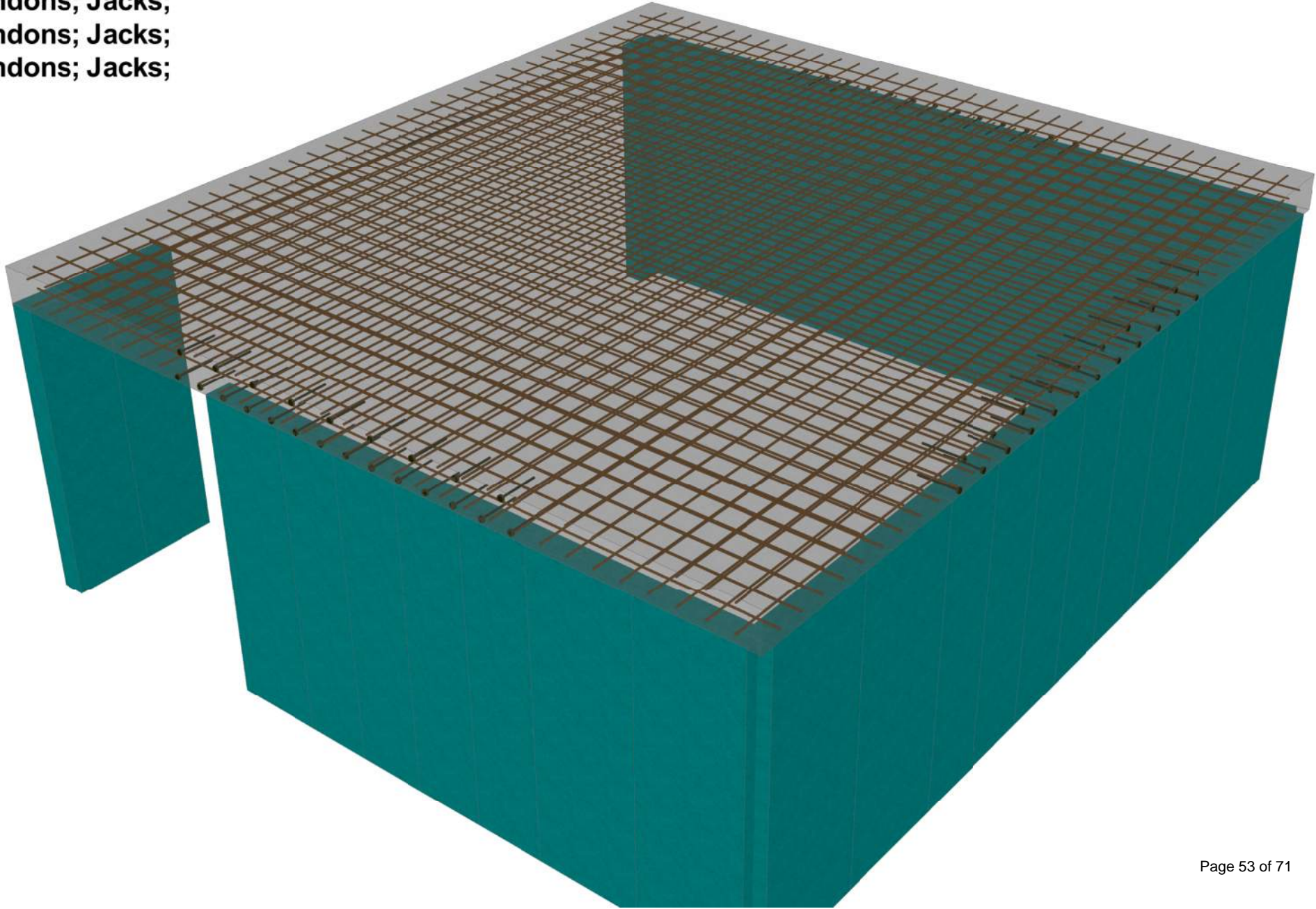

# Service Design: Latitude Status Plan

Service Design: User Lines; User Notes; User Dimensions; Latitude Span Designs; Span Design Numbers; Span Design Status

Drawing Import: User Lines; User Notes; User Dimensions;

Element: Wall Elements Below; Wall Elements Above; Wall Element Outline Only; Column Elements Below; Column Elements A

Scale = 1:70

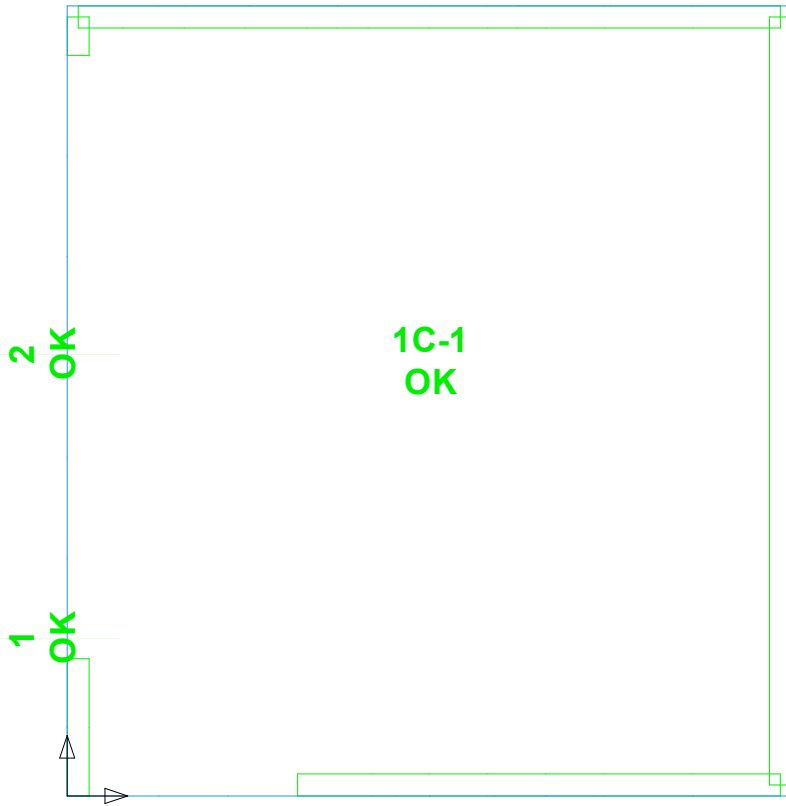

# Service Design: Latitude Top Reinforcement Plan

Service Design: User Lines; User Notes; User Dimensions; Latitude Span Designs; Span Design Top Bars; Span Design Bar De  
Drawing Import: User Lines; User Notes; User Dimensions;  
Element: Wall Elements Below; Wall Elements Above; Wall Element Outline Only; Column Elements Below; Column Elements A  
Reinforcement: Top Face Concentrated Reinf.; Both Faces Concentrated Reinf.; Auto Face Concentrated Reinf.; Concentrated I  
Scale = 1:70

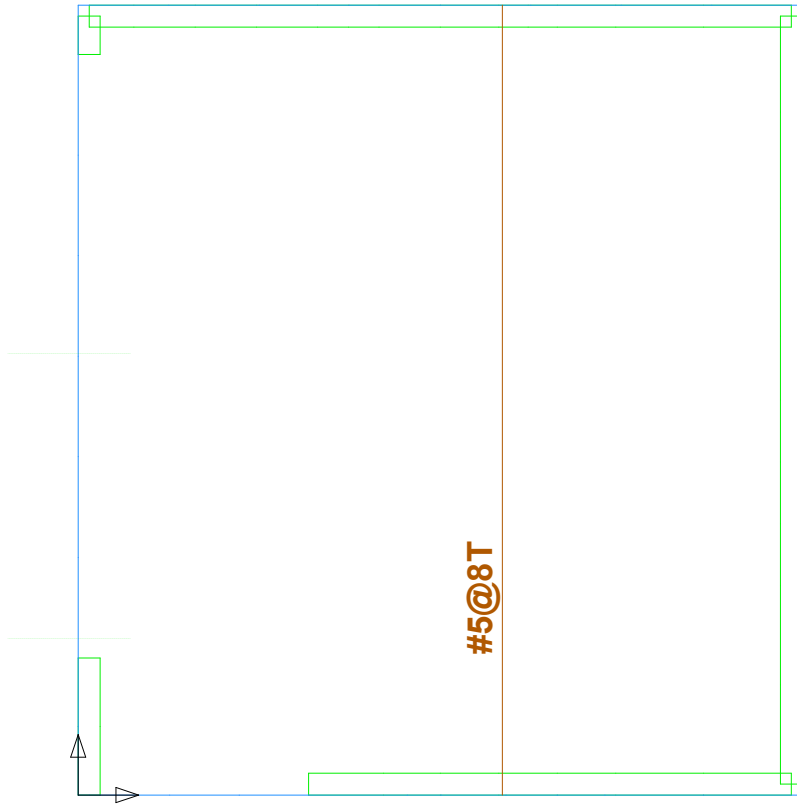

# Service Design: Latitude Top Reinforcement Plan (2)



# Service Design: Latitude Bottom Reinforcement Plan

Service Design: User Lines; User Notes; User Dimensions; Latitude Span Designs; Span Design Bottom Bars; Span Design Ba  
Drawing Import: User Lines; User Notes; User Dimensions;  
Element: Wall Elements Below; Wall Elements Above; Wall Element Outline Only; Column Elements Below; Column Elements A  
Reinforcement: Bottom Face Concentrated Reinf.; Both Faces Concentrated Reinf.; Auto Face Concentrated Reinf.; Concentrat  
Scale = 1:70

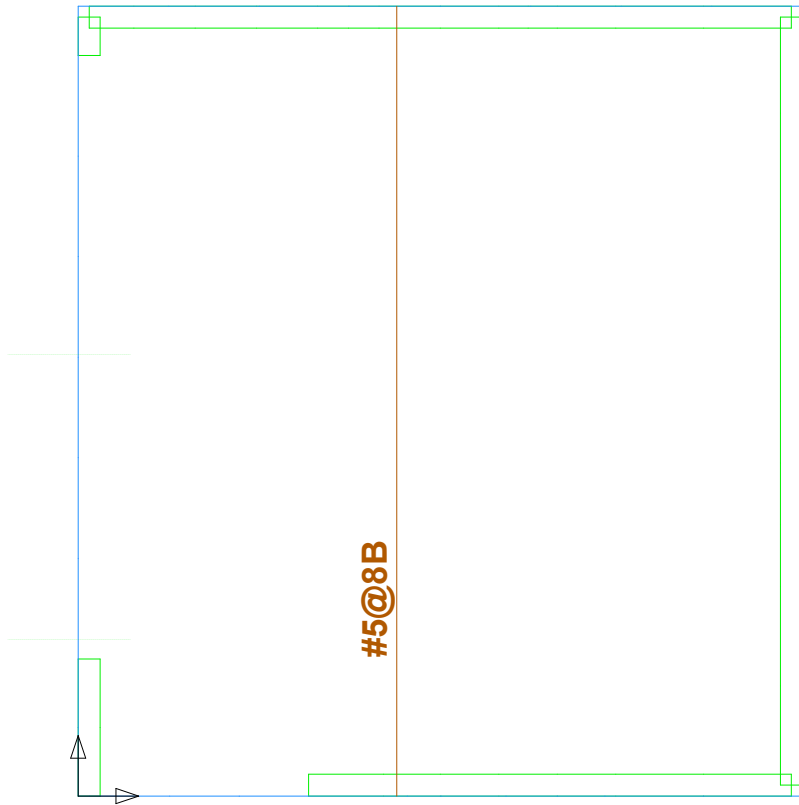

# Service Design: Latitude Bottom Reinforcement Plan (2)

# Service Design: Longitude Status Plan

Service Design: User Lines; User Notes; User Dimensions; Longitude Span Designs; Span Design Numbers; Span Design Status

Drawing Import: User Lines; User Notes; User Dimensions;

Element: Wall Elements Below; Wall Elements Above; Wall Element Outline Only; Column Elements Below; Column Elements Above

Scale = 1:70

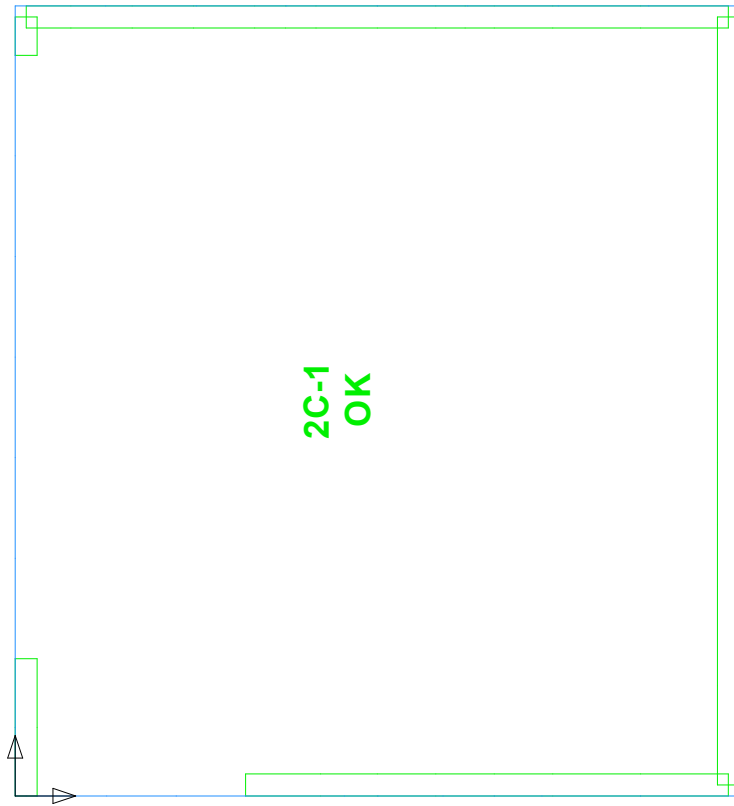

# Service Design: Longitude Top Reinforcement Plan

Service Design: User Lines; User Notes; User Dimensions; Longitude Span Designs; Span Design Top Bars; Span Design Bar  
Drawing Import: User Lines; User Notes; User Dimensions;  
Element: Wall Elements Below; Wall Elements Above; Wall Element Outline Only; Column Elements Below; Column Elements A  
Reinforcement: Top Face Concentrated Reinf.; Both Faces Concentrated Reinf.; Auto Face Concentrated Reinf.; Concentrated I  
Scale = 1:70

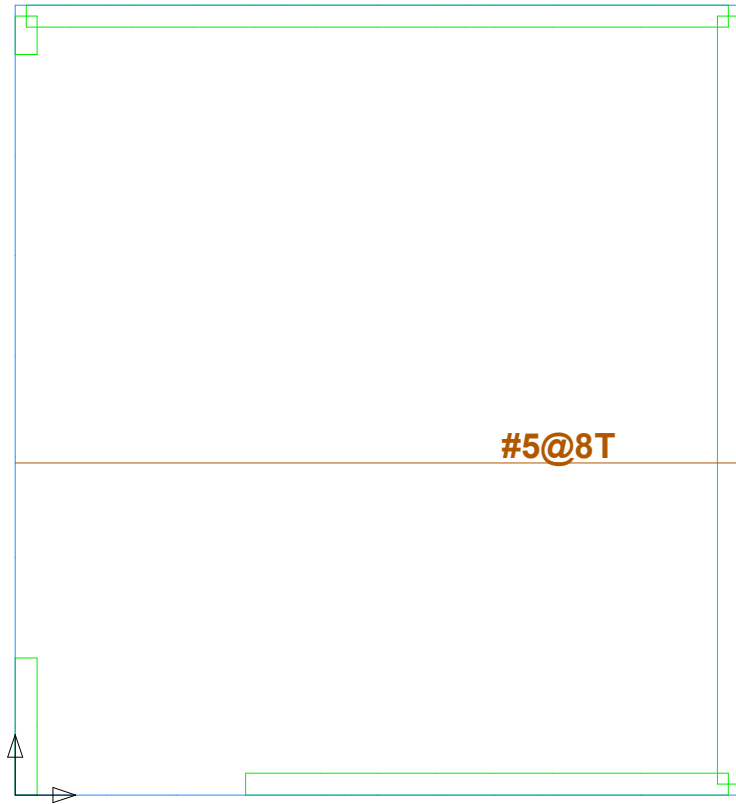

# Service Design: Longitude Top Reinforcement Plan (2)

# Service Design: Longitude Bottom Reinforcement Plan

Service Design: User Lines; User Notes; User Dimensions; Longitude Span Designs; Span Design Bottom Bars; Span Design E

Drawing Import: User Lines; User Notes; User Dimensions;

Element: Wall Elements Below; Wall Elements Above; Wall Element Outline Only; Column Elements Below; Column Elements A

Reinforcement: Bottom Face Concentrated Reinf.; Both Faces Concentrated Reinf.; Auto Face Concentrated Reinf.; Concentrat

Scale = 1:70

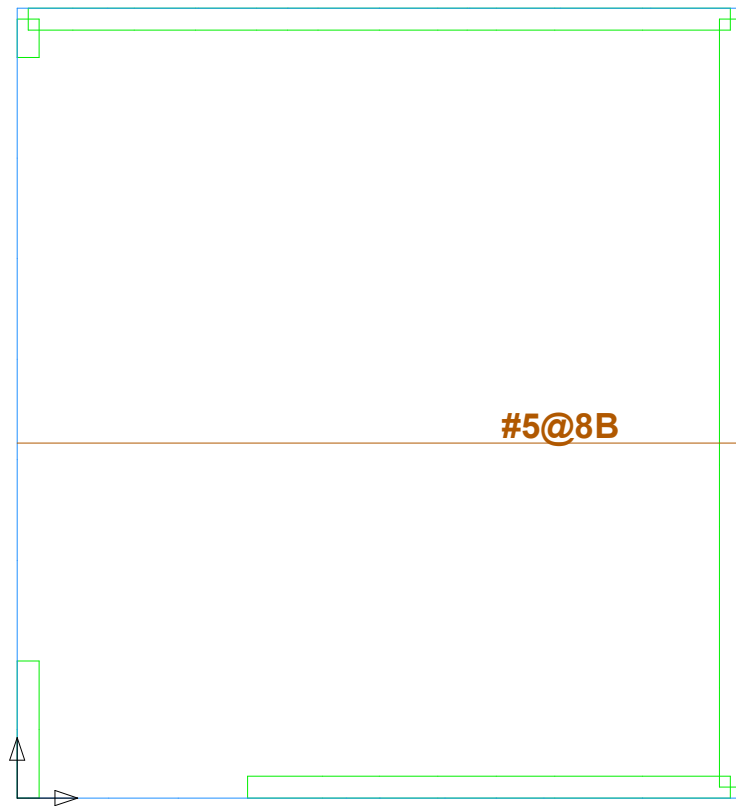

# Service Design: Longitude Bottom Reinforcement Plan (2)

# Service Design: Top Stress Plan

Service Design: User Lines; User Notes; User Dimensions; Latitude Span Designs; Longitude Span Designs; Latitude DS Design

Drawing Import: User Lines; User Notes; User Dimensions;

Element: Wall Elements Below; Wall Elements Above; Wall Element Outline Only; Column Elements Below; Column Elements A

Scale = 1:70

Service Design - Section Analysis Plot: (Gross Section Top Concrete Stress)(Context: Max Capacity,Max Demand)

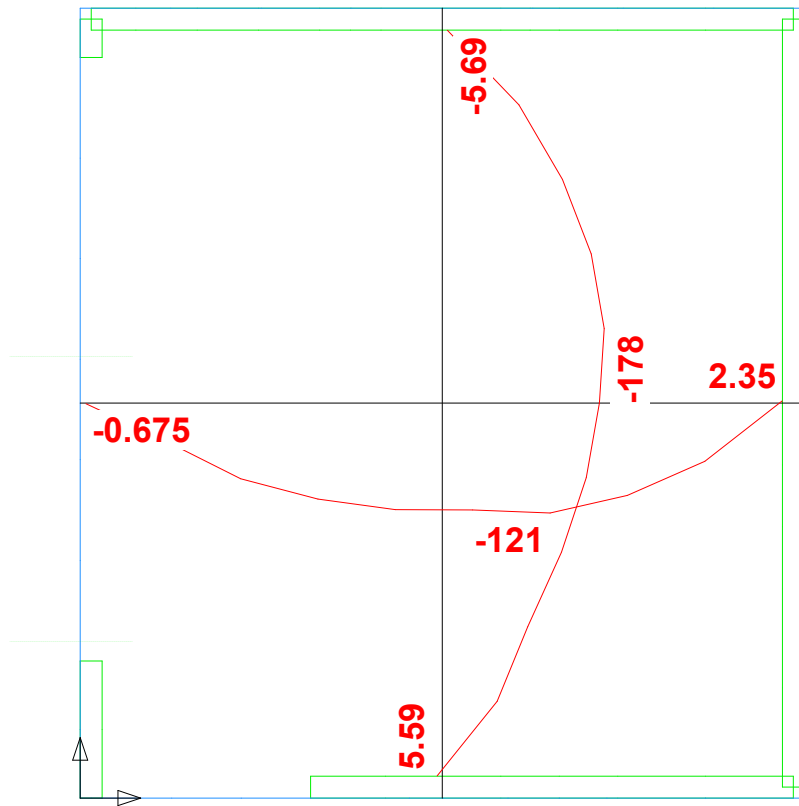



# Service Design: Top Stress Plan (2)

# Service Design: Centroid Stress Plan

Service Design: User Lines; User Notes; User Dimensions; Latitude Span Designs; Longitude Span Designs; Latitude DS Design

Drawing Import: User Lines; User Notes; User Dimensions;

Element: Wall Elements Below; Wall Elements Above; Wall Element Outline Only; Column Elements Below; Column Elements A

Scale = 1:70

Service Design - Section Analysis Plot: (Gross Section Centroid Concrete Stress)(Context: Max Demand,Min Demand)

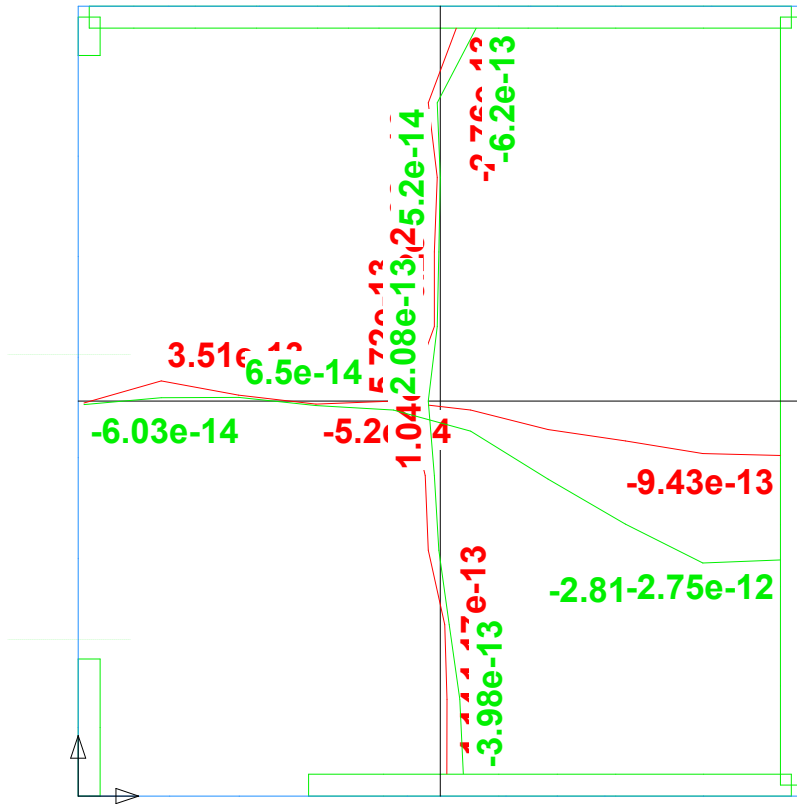

# Service Design: Centroid Stress Plan (2)

# Service Design: Bottom Stress Plan

Service Design: User Lines; User Notes; User Dimensions; Latitude Span Designs; Longitude Span Designs; Latitude DS Design

Drawing Import: User Lines; User Notes; User Dimensions;

Element: Wall Elements Below; Wall Elements Above; Wall Element Outline Only; Column Elements Below; Column Elements A

Scale = 1:70

Service Design - Section Analysis Plot: (Gross Section Bottom Concrete Stress)(Context: Max Capacity,Max Demand)

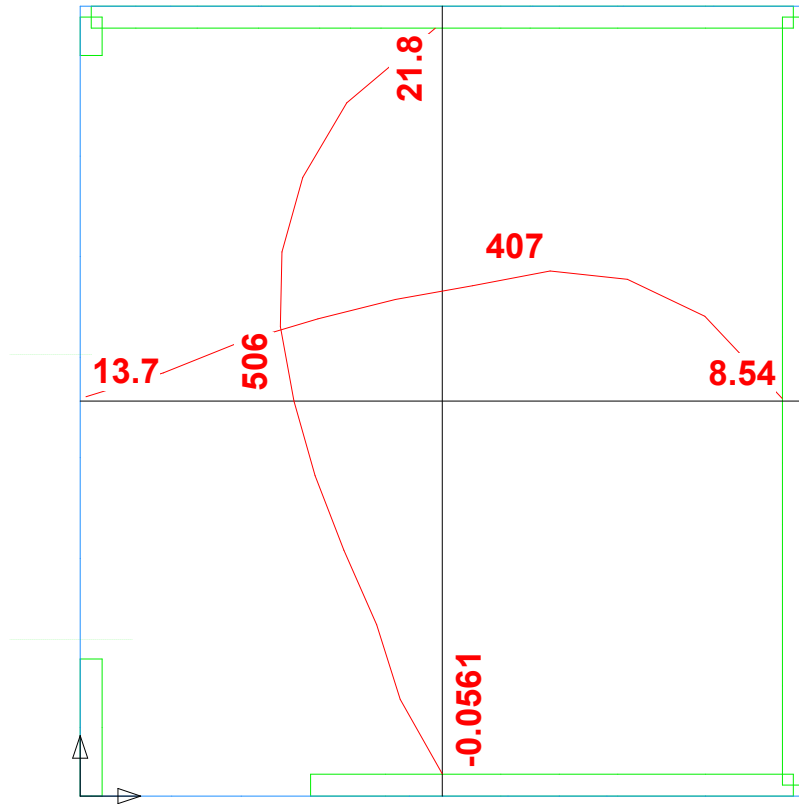

# Service Design: Bottom Stress Plan (2)

# Design Status: Status Plan

Design Status: User Lines; User Notes; User Dimensions; Latitude Span Designs; Longitude Span Designs; Span Design Number

Drawing Import: User Lines; User Notes; User Dimensions;

Element: Wall Elements Below; Wall Elements Above; Wall Element Outline Only; Column Elements Below; Column Elements Above

Scale = 1:70

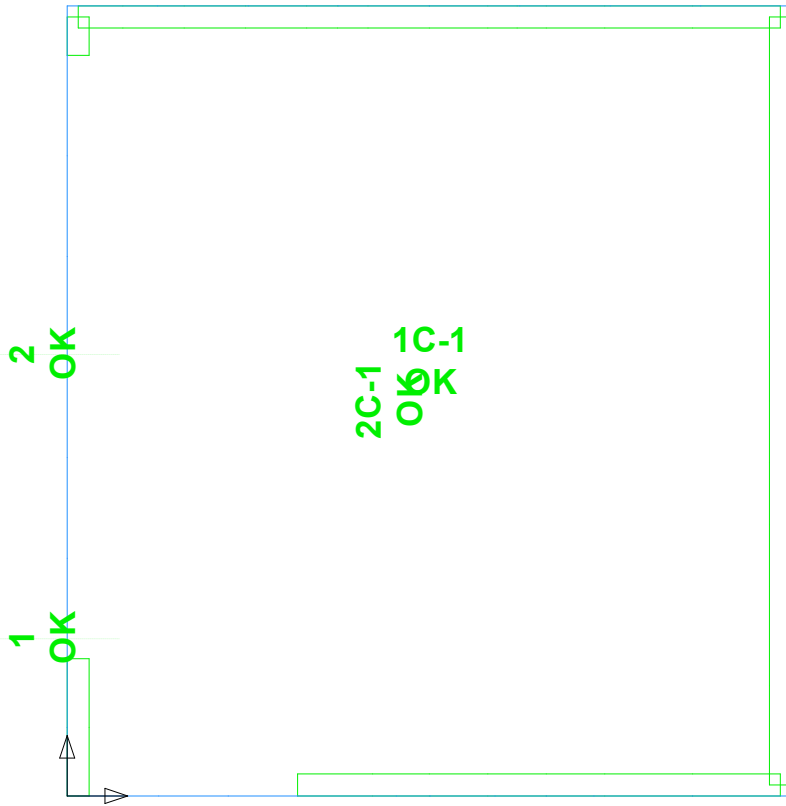

# Estimate

## Concrete Costs

Materials:	100 per yd <sup>3</sup>	x	19.56 yd <sup>3</sup>	=	1956
Labor:	50 per yd <sup>3</sup>	x	19.56 yd <sup>3</sup>	=	977.8
Total:	150 per yd <sup>3</sup>	x	19.56 yd <sup>3</sup>	=	2933

## Post-Tensioning Costs

Materials:	1 per pounds	x	0 pounds	=	0
Labor:	0.5 per pounds	x	0 pounds	=	0
Total:	1.5 per pounds	x	0 pounds	=	0

## Formwork Costs

Materials:	1 per ft <sup>2</sup>	x	528 ft <sup>2</sup>	=	528
Labor:	1 per ft <sup>2</sup>	x	528 ft <sup>2</sup>	=	528
Total:	2 per ft <sup>2</sup>	x	528 ft <sup>2</sup>	=	1056

## Mild Steel Reinforcing Costs

Materials:	1000 per tons	x	1.643 tons	=	1643
Labor:	500 per tons	x	1.643 tons	=	821.5
Total:	1500 per tons	x	1.643 tons	=	2465

## SSR Costs

Materials:	2 per stud	x	0 studs	=	0
Labor:	1 per stud	x	0 studs	=	0
Total:	3 per stud	x	0 studs	=	0

## Total Costs

Materials:	7.816 per ft <sup>2</sup>	x	528 ft <sup>2</sup>	=	4127
Labor:	4.408 per ft <sup>2</sup>	x	528 ft <sup>2</sup>	=	2327
Total:	12.22 per ft <sup>2</sup>	x	528 ft <sup>2</sup>	=	6454